

MACHEREY-NAGEL

User manual

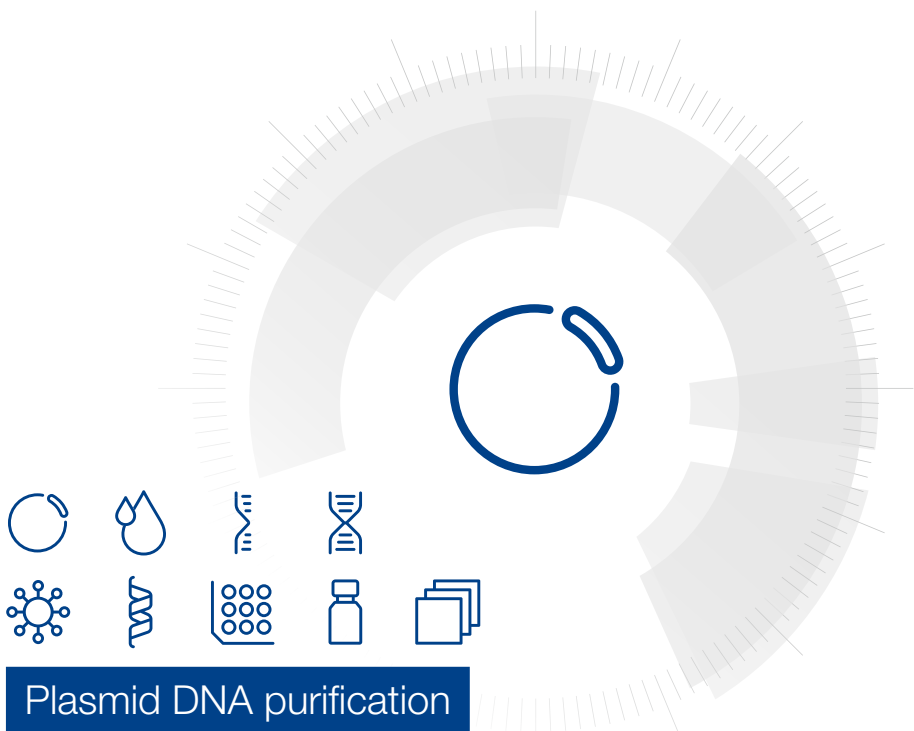

Plasmid DNA purification

- NucleoSpin® 96 Plasmid
- NucleoSpin® 96 Plasmid Core Kit

June 2024 / Rev. 07

Contact MN

Germany and international

MACHEREY-NAGEL GmbH & Co. KG
Valenciennener Str. 11 · 52355 Düren · Germany
Tel.: +49 24 21 969-0
Toll-free: 0800 26 16 000 (Germany only)
E-mail: info@mn-net.com

Technical Support Bioanalysis

Tel.: +49 24 21 969-333
E-mail: support@mn-net.com

USA

MACHEREY-NAGEL Inc.
924 Marcon Blvd. · Suite 102 · Allentown PA, 18109 · USA
Toll-free: 888 321 6224 (MACH)
E-mail: sales-us@mn-net.com

France

MACHEREY-NAGEL SAS
1, rue Gutenberg – BP135 · 67720 Hoerdt Cedex · France
Tel.: +33 388 68 22 68
E-mail: sales-fr@mn-net.com

MACHEREY-NAGEL SAS (Société par Actions Simplifiée) au capital de 186600 €
Siret 379 859 531 00020 · RCS Strasbourg B379859531 · N° intracommunautaire FR04 379 859 531

Switzerland

MACHEREY-NAGEL AG
Hirsackerstr. 7 · 4702 Oensingen · Switzerland
Tel.: +41 62 388 55 00
E-mail: sales-ch@mn-net.com

Table of contents

1	Components	4
1.1	Kit contents	4
1.2	Reagents to be supplied by user	5
1.3	About this user Manual	5
2	Product description	6
2.1	The basic principle	6
2.2	Kit specifications	6
2.3	Required hardware	7
2.4	Recommended accessories for use of the NucleoSpin® 96 Plasmid Core Kit	8
2.5	Automated processing on robotic platforms	9
2.6	Growth of bacterial cultures	9
2.6.1	Selection of culture media	9
2.6.2	Cultivation of bacteria in a Square-well Block	9
2.6.3	Cultivation of bacteria in tubes	10
2.7	Elution procedures	11
3	Storage conditions and preparation of working solutions	12
4	Safety instructions	13
4.1	Disposal	13
5	Protocols	14
5.1	NucleoSpin® 96 Plasmid – manual vacuum processing	14
5.2	NucleoSpin® 96 Plasmid – elution of DNA using a centrifuge	23
5.3	NucleoSpin® 96 Plasmid – centrifuge processing	24
6	Appendix	27
6.1	Troubleshooting	27
6.2	Ordering information	29
6.3	Product use restriction / warranty	29

1 Components

1.1 Kit contents

NucleoSpin® 96 Plasmid			
REF	1 × 96 preps 740625.1	4 × 96 preps 740625.4	24 × 96 preps ¹ 740625.24
Resuspension Buffer A1	75 mL	150 mL	6 × 150 mL
Lysis Buffer A2 with Lyse Control	75 mL	150 mL	6 × 150 mL
Neutralization Buffer A3	100 mL	200 mL	6 × 200 mL
Wash Buffer AW	100 mL	400 mL	6 × 400 mL
Wash Buffer A4 (Concentrate) ²	100 mL	2 x 100 mL	12 x 100 mL
Elution Buffer AE ³	30 mL	125 mL	6 × 125 mL
RNase A (lyophilized) ²	30 mg	60 mg	6 × 60 mg
NucleoSpin® Plasmid Binding Plate (white rings)	1	4	24
NucleoSpin® Plasmid Filter Plate (violet rings)	1	4	24
Culture Plate (including Gas-permeable Foil)	1	4	24
Elution Plate (including Self adhering Foil)	1	4	24
MN Wash Plate	1	4	24
User manual	1	1	6

¹ The kit for 24 × 96 preparations (REF 740625.24) consists of 6 x REF 740625.4.

² For preparation of working solutions and storage conditions see section 3.

³ Composition of Elution Buffer AE: 5 mM Tris/HCl, pH 8.5

Kit contents (continued)

REF	NucleoSpin® 96 Plasmid Core Kit	
	4 × 96 preps 740616.4	24 × 96 preps ¹ 740616.24
Resuspension Buffer A1	150 mL	6 × 150 mL
Lysis Buffer A2 with Lyse Control	150 mL	6 × 150 mL
Neutralization Buffer A3	200 mL	6 × 200 mL
Wash Buffer A4 Concentrate) ²	2 × 100 mL	12 × 100 mL
Elution Buffer AE ³	125 mL	6 × 125 mL
RNase A (lyophilized) ²	60 mg	6 × 60 mg
NucleoSpin® Plasmid Binding Plate (white rings)	4	24
NucleoSpin® Plasmid Filter Plate (violet rings)	4	24
User manual	1	6

1.2 Reagents to be supplied by user

- 96 – 100 % ethanol

1.3 About this user Manual

It is recommended to read the instructions of this user manual carefully before use. All technical literature is also available on the internet at www.mn-net.com.

Please contact Technical Service regarding information about changes of the current user manual compared to previous or updated revisions.

¹ The kit for 24 × 96 preparations (REF 740616.24) consists of 6 × REF 740616.4.

² For preparation of working solutions and storage conditions see section 3.

³ Composition of Elution Buffer AE: 5 mM Tris/HCl, pH 8.5

2 Product description

2.1 The basic principle

The **NucleoSpin® 96 Plasmid** procedure is a modified version of the Birnboim and Doly¹ alkaline lysis plasmid Mini prep protocol. Bacterial cultures are harvested by an initial centrifugation step. After resuspension of the pelleted bacteria (Buffer A1) and alkaline cell lysis (Buffer A2), a neutralization and binding buffer (Buffer A3) containing chaotropic salts is added. Resulting bacterial crude lysates are cleared by vacuum filtration with the NucleoSpin® Plasmid Filter Plate. The cleared lysates containing the plasmid DNA are collected into the NucleoSpin® Plasmid Binding Plate. The chaotropic salt leads to a reversible adsorption of the plasmid DNA to the NucleoSpin® silica membrane during the second vacuum-filtration step. High purity of the final plasmid DNA preparation is achieved by complete removal of cellular contaminants, salts, detergents, and other compounds by subsequent washing steps. Highly pure plasmid DNA is finally eluted with Elution Buffer AE (5 mM Tris / HCl, pH 8.5) or water (pH 8.0–8.5) and can directly be used for downstream applications.

We can provide personalized support, protocol information, or verified scripts for numerous platforms. For more information, please contact our technical support or visit www.mn-net.com/automation.

2.2 Kit specifications

- **NucleoSpin® 96 Plasmid** is designed for the manual or automated large-scale purification of high-copy plasmid DNA from *E.coli* in the 96-well plate format.
- **NucleoSpin® 96 Plasmid** kits (REF 740625.1/.4/.24) are supplied with all accessory plates for highest convenience.
- The **NucleoSpin® 96 Plasmid Core Kit** (REF 740616.4/.24) provides the buffers, RNase A, NucleoSpin® Plasmid Filter Plates, and NucleoSpin® Plasmid Binding Plates. Accessory components (e.g., culture plate, elution plate, MN Wash Plate, and Wash Buffer AW) are not provided with the core kit but can be individually selected from a variety of suitable accessories (see section 2.4 for further information). This allows highest flexibility for the user.
Please note: All given specifications or information in this manual refer equally to the **NucleoSpin® 96 Plasmid** kit (REF 740625.1/.4/.24) as well as to the **NucleoSpin® 96 Plasmid Core Kit** (REF 740616.4/.24).
- The kits allow for easy automation on common liquid handling instruments. For more information about the automation process and the availability of ready-to-run scripts

¹ Birnboim, H.C. & Doly, J. (1979) *Nucleic Acids Res.* 7, 1513–1523.

for certain platforms please refer to section 2.5 and /or contact your local distributor or MN directly.

- Using the **NucleoSpin® 96 Plasmid** kits allow simultaneous manual processing of up to 96 samples typically within less than 45 minutes. Actual processing time depends on the configuration of the liquid handling system used.
- Typically yields of 5 – 15 µg plasmid DNA can be purified from 1.5 mL overnight cultures.
- Yield depends on copy number and plasmid size, selected culture medium, and bacterial host strain.
- The DNA binding capacity is about 20 µg. The final concentration of the eluted DNA is 50 – 200 ng/µL (depending on the elution buffer volume and the bacterial culture).
- Typically, the A_{260}/A_{280} ratio is > 1.8. Eluted DNA is ready to use for many downstream applications.

Table 1: Kit specifications at a glance

Parameter	NucleoSpin® 96 Plasmid
Format	96-well plates
Use	For research use only
Processing	Manual or automated, vacuum
Lysate clarification	96-well filter plates
Sample material	1 – 5 mL <i>E. coli</i> culture
Vector size	< 15 kbp
Typical yield	4 – 6 µg/mL <i>E. coli</i> culture
Elution volume	75 – 150 µL
Preparation time	45 min/plate
Binding capacity	20 µg

2.3 Required hardware

This kit is intended for use under vacuum. A support protocol for elution under centrifugation is included (see section 5.2).

A support protocol for complete processing under centrifugation is available from our technical service (tech-bio@mn-net.com).



The **NucleoSpin® 96 Plasmid** kits can be used **manually** with the NucleoVac 96 Vacuum Manifold (see ordering information, section 6.2). Additionally, a suitable centrifuge for harvesting the bacteria (either plate or tube centrifuge) and for the optimal elution step under centrifugation is required.

2.4 Recommended accessories for use of the NucleoSpin® 96 Plasmid Core Kit

The **NucleoSpin® 96 Plasmid Core Kit** provides buffers (except optional Wash Buffer AW), RNase A, and NucleoSpin® Filter / Binding Plates. Accessory plates (e.g., culture blocks, elution plates) are not provided with the core kit. The user can individually select additional consumables from a variety of suitable accessory plates according to his requirements for highest flexibility.

For use of **NucleoSpin® 96 Plasmid Core Kit**, follow the standard protocols (see section 5.1 or 5.2, respectively).

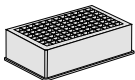
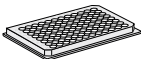
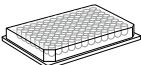
Recommended accessories for use of the **NucleoSpin® 96 Plasmid Core Kit** are available from MACHEREY-NAGEL. For ordering information, please refer to section 6.2.

Protocol step	Suitable consumables, not supplied with the core kits	Remarks
1. Cultivation of bacteria	Culture Plates 	Square-well Blocks with Gas-permeable Foil
9. Wash step	MN Wash Plates  Buffer AW	MN Wash Plate minimizes the risk of cross contamination (vacuum processing only) Recommended additional wash buffer for bacterial host strain with high endogenous nuclease activity (e.g., <i>E. coli</i> HB 101, BMH 71-18 mutS, JM, or any wildtype strains) or for improvement of sequencing results
13. Elution	Elution Plate U-bottom  or Rack of Tube Strips (including Cap Strips) 	Not suitable for elution by centrifugation

2.5 Automated processing on robotic platforms

NucleoSpin® 96 Plasmid can be used fully automated on many common laboratory workstations. For the availability of scripts and general considerations about adapting **NucleoSpin® 96 Plasmid** on a certain workstation, please contact MN. Full processing under vacuum enables complete automation without the need of centrifugation steps, regarding the drying of the binding membrane and elution step.

The risk of cross-contamination is reduced by optimized vacuum settings during the elution step and by the improved shape of the outlets of the NucleoSpin® Plasmid Binding Plate.

Drying of the NucleoSpin® Plasmid Binding Plate under vacuum is sufficient because the bottom of the plate is protected from residues of wash buffer during the washing steps by the MN Wash Plate. As a result, we recommend trying to integrate the MN Wash Plate into the automated procedure. The MN Frame (see ordering information) can be used to position the disposable MN Wash Plate inside the vacuum chamber. This also reduces the risk of cross-contamination, as common metal adaptors tend to get contaminated by gDNA. Thorough cleaning of the vacuum chamber is recommended after each run to prevent forming of gDNA-containing aerosols.

Visit MN online at www.mn-net.com or contact your local MACHEREY-NAGEL distributor for technical support regarding hardware, software, setup instructions, and selection of the protocol. .

2.6 Growth of bacterial cultures

2.6.1 Selection of culture media

The cultivation of cells is recommended at 37 °C in LB (Luria-Bertani) medium at constant shaking (200–250 rpm). Alternatively, rich media like 2 x YT or TB (Terrific Broth) can be used. By using 2 x YT or TB, bacteria grow faster and reach the stationary phase much earlier than in LB medium (≤ 12 h) in culture tubes or flasks. This may lead to a higher percentage of dead or starving cells when starting the preparation. The resulting plasmid DNA from overgrown cultures may be partially degraded or contaminated with chromosomal DNA.

2.6.2 Cultivation of bacteria in a Square-well Block

Use the 96-well Square-well Block (Culture Plate; not included in the core kits) for growing bacteria. Add 1.2–1.5 mL of selected medium (with appropriate antibiotic, e.g., 100 µg/mL ampicillin) to each well of the Square-well Block. To avoid cross-contamination due to spillage during incubation, do not exceed a total culture volume of 1.5 mL. Inoculate each well with a single bacterial colony. Cover the Square-well Block with the Gas-permeable Foil. Grow the culture in a suitable incubator at 37 °C for 16–24 h with vigorous shaking (200–400 rpm). The Square-well Block may be fixed to the shaker with large-size flask clamps (for 2-L flasks) or tape.

Note: The yield of plasmid DNA depends on growth conditions, bacterial strain, and cell density of the culture as well as on the size and copy number of the vector. Use of high-copy number plasmids such as pUC, pBluescript, or pGEM and E. coli strains like DH5α

or XL1 Blue are recommended. Growth times of 16–24 h are usually sufficient. However, for poorly growing bacteria, prolonged incubation times of up to 30 h may be required.

2.6.3 Cultivation of bacteria in tubes

Use 1–5 mL of appropriate culture medium. Depending on the bacterial strain and copy number of the plasmid, up to 5 mL LB medium or 2.5 mL 2 x YT or 2.5 mL TB medium can be used. Grow bacteria with vigorous shaking (200–250 rpm) for 10–14 h.

Optional: If the liquid handling instrument does not allow for the use of selected culture tubes, transfer the bacterial culture from the tubes into a suitable Square-well Block. For this, transfer 1.5 mL of the culture to each well of the Square-well Block. Harvest the cultures by centrifugation. Discard supernatant. Usually 1.5 mL of culture are sufficient for DNA preparation. However, if necessary, add additional 1.0–1.5 mL bacterial culture to each well of the Square-well Block, centrifuge again, and discard the supernatant.

Do not use more than 5 mL LB culture or 2.5 mL rapid growing bacterial strain (using 2 x YT or TB medium) because lysis efficiency might be lower when using cell pellets which are too large.

2.7 Elution procedures

See the following table for correlation between the dispensed elution buffer volume and typical recoveries following the standard protocol under vacuum.

The recommended dispense volume of elution buffer is 125 μL .

Table 2: Correlation between dispensed elution buffer volume and typical recovery

Dispensed elution buffer	75 μL	100 μL	125 μL	150 μL	175 μL
Recovered elution buffer containing PCR-products	30 \pm 5 μL	55 \pm 5 μL	80 \pm 5 μL	105 \pm 5 μL	130 \pm 5 μL

- ◆ Concentration, ng/ μL
- Recovered DNA, μg
- ▲ Recovery, %

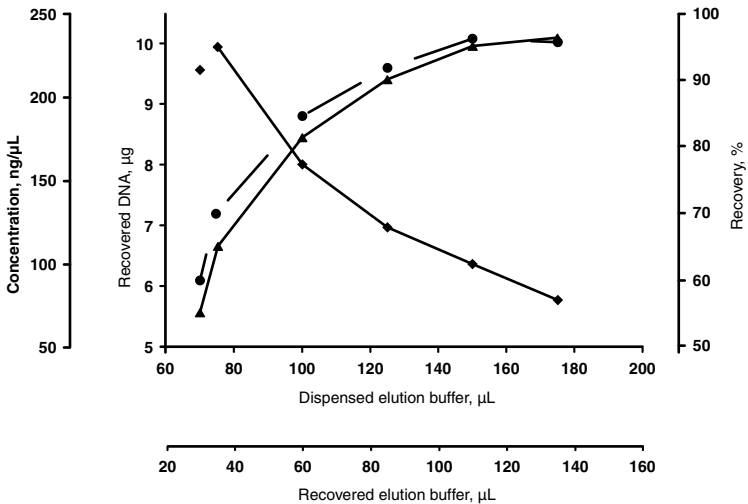

Figure 1 Recovery rate and concentration depend on elution volume.
10 μg of pBluescript plasmid were purified with NucleoSpin[®] 96 Plasmid and eluted with the indicated elution buffer volumes.

3 Storage conditions and preparation of working solutions

Attention: Buffers A3 and AW contain chaotropic salts which are irritant. Buffer A2 contains SDS and sodium hydroxide which are irritant and hazardous. Wear gloves and goggles!

CAUTION: Buffers A3 and AW contain guanidine hydrochloride which can form highly reactive compounds when combined with bleach (sodium hypochlorite). DO NOT add bleach or acidic solutions directly to the sample-preparation waste.

Storage conditions:

- All kit components can be stored at room temperature (15–25 °C) and are stable until: see package label. Always keep buffer bottles tightly closed, especially if buffers are preheated during the preparation. Sodium dodecyl sulfate (SDS) in Buffer A2 may precipitate if stored at temperatures below 20 °C. If a precipitate is observed in Buffer A2, incubate the bottle at 30–40 °C for several minutes and mix well.

Before starting any **NucleoSpin® 96 Plasmid** protocol, prepare the following:

- Before the first use of the kit, add 1 mL of **Buffer A1** to the **RNase A** vial and vortex. Transfer all of the resulting solution into the Buffer A1 bottle and mix thoroughly. Indicate date of RNase A addition. Store Buffer A1 containing RNase A at 4 °C. The solution will be stable at this temperature for at least six months.
- Wash Buffer A4:** Add the indicated volume of ethanol (96–100 %) to Buffer A4 Concentrate before use. Mark the label of the bottle to indicate that ethanol was added.

NucleoSpin® 96 Plasmid			
REF	1 × 96 preps 740625.1	4 × 96 preps 740625.4	24 × 96 preps 740625.24
Wash Buffer A4 (Concentrate)	100 mL Add 400 mL ethanol	200 mL Add 800 mL ethanol to each bottle	6 × 200 mL Add 800 mL ethanol to each bottle

NucleoSpin® 96 Plasmid Core Kit		
REF	4 × 96 preps 740616.4	24 × 96 preps 740616.24
Wash Buffer A4 (Concentrate)	2 × 100 mL Add 400 mL ethanol to each bottle	12 × 100 mL Add 400 mL ethanol to each bottle

4 Safety instructions

When working with the **NucleoSpin® 96 Plasmid (Core)** kit wear suitable protective clothing (e.g., lab coat, disposable gloves, and protective goggles). For more information consult the appropriate Material Safety Data Sheets (MSDS available online at <http://www.mn-net.com/msds>).



Caution: Guanidine hydrochloride in buffer A3 and AW can form highly reactive compounds when combined with bleach! Thus, do not add bleach or acidic solutions directly to the sample preparation waste.

The waste generated with the **NucleoSpin® 96 Plasmid (Core)** kit has not been tested for residual infectious material. A contamination of the liquid waste with residual infectious material is highly unlikely due to strong denaturing lysis buffer treatment but it cannot be excluded completely. Therefore, liquid waste must be considered infectious and should be handled and discarded according local safety regulations.

4.1 Disposal

Dispose hazardous, infectious or biologically contaminated materials in a safe and acceptable manner and in accordance with all local and regulatory requirements.

5 Protocols

5.1 NucleoSpin® 96 Plasmid – manual vacuum processing

- For hardware requirements, refer to section 2.3.
- For detailed information regarding the vacuum manifold setup, see page 16 and 17.
- For detailed information on each step, see page 19.
- For use of the NucleoSpin® 96 Plasmid Core Kit (REF 740616.4/.24), refer to section 2.4 regarding recommended accessories.

Before starting the preparation:

- Check if Buffer A1 and Buffer A4 were prepared according to section 3.
- Set up the vacuum according to the scheme.

Protocol at a glance

1	Cultivate and harvest bacterial cells	1.5 mL–5 mL LB or up to 2.5 mL 2 x YT or TB 10 min, 1,000 x g
2	Resuspend bacterial cells	250 µL A1 Mix or shake
3	Lyse bacterial cells	250 µL A2 RT, 2–5 min Shake
4	Neutralize	350 µL A3 Mix or shake
Prepare vacuum manifold for lysate clearing step		
5	Transfer crude lysates to NucleoSpin® Plasmid Filter Plate (violet rings)	
6	Clear crude lysates by vacuum filtration directly into the NucleoSpin® Plasmid Binding Plate (white rings) <i>Optional: Incubate 1–3 min before applying vacuum</i>	-0.2 to -0.4 bar*, 1–5 min

* Reduction of atmospheric pressure

7	Reassemble vacuum manifold Discard NucleoSpin® Plasmid Filter Plate Remove NucleoSpin® Plasmid Binding Plate with cleared lysates and insert MN Wash Plate Place NucleoSpin® Plasmid Binding Plate on top of the manifold	
8	Bind DNA to silica membrane of the NucleoSpin® Plasmid Binding Plate by applying vacuum	-0.2 to -0.4 bar*, 1 min
9	Wash silica membrane	(Optional: 600 µL AW) 900 µL A4 900 µL A4 – 0.2 to -0.4 bar*, 1 min each step
10	Remove MN Wash Plate	
11	Dry NucleoSpin® Plasmid Binding Plate by applying vacuum <i>Optional: Dry the outlets of the NucleoSpin® Plasmid Binding Plate by placing it on a sheet of filter paper before applying vacuum</i>	Full vacuum 10–15 min (run pump continuously)*
12	Insert Elution Plate U-bottom	
13	Elute plasmid DNA <i>Optional: Incubate 1–3 min</i>	75–150 µL AE -0.4 to -0.6 bar*, 1 min

* Reduction of atmospheric pressure

Setup of vacuum manifold: Lysate clearing

Lysate clearing

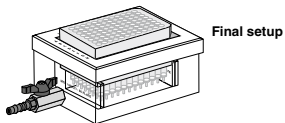
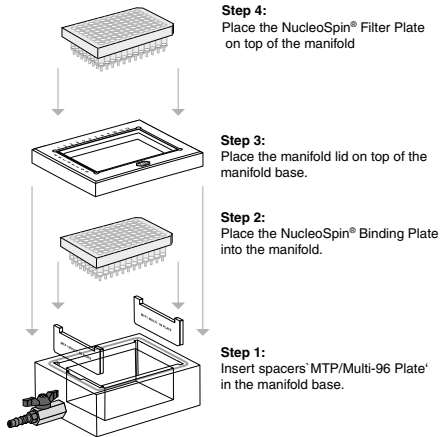

Setup of vacuum manifold: Binding /Washing /Elution steps

Binding /Washing steps

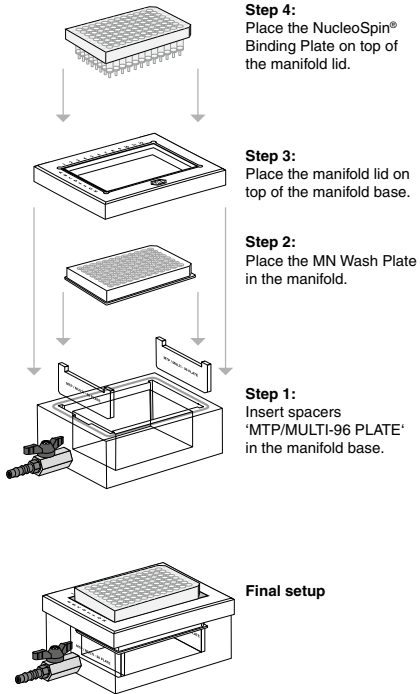

Elution step

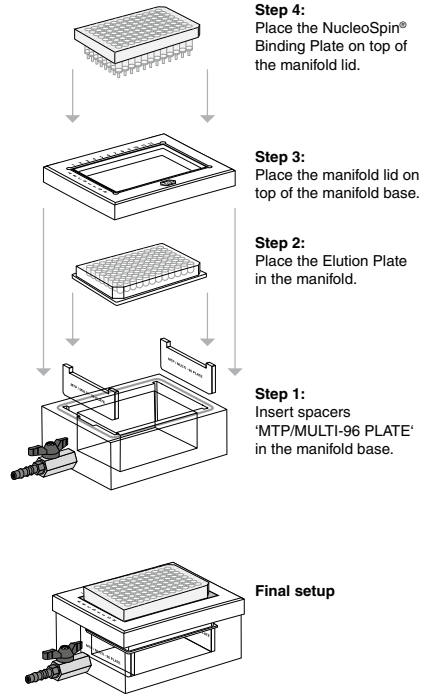

Setup of the [MPE]² positive pressure module

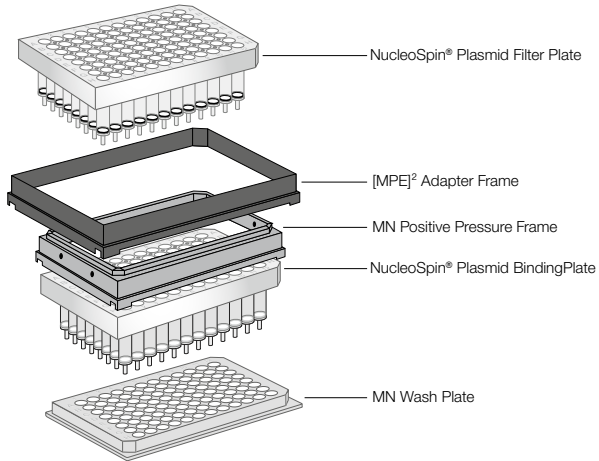

Detailed protocol

For processing of **NucleoSpin® 96 Plasmid** under vacuum the NucleoVac 96 Vacuum Manifold is required.

Before starting the preparation:

- Check if Buffer A1 and Buffer A4 were prepared according to section 3.
-

1 Cultivate and harvest bacterial cells

Centrifuge the bacteria cultures (1.5–5 mL LB or up to 2.5 mL 2 x YT or TB) for **10 min at 1,000 x g**.

It is highly recommended centrifuging the bacterial cultures under the above mentioned conditions. Centrifugation at higher *g*-forces might produce tight pellets which are more difficult to resuspend.

Discard supernatant. Remove residual medium by tapping tube or plate upside down on a clean paper sheet or soft tissue.

Optional: Transfer bacteria cultures grown in tubes to a Square-well Block. Alternatively, perform the next three steps in the tubes.

2 Resuspend bacterial cells

Add **250 µL Buffer A1 with RNase A** to each sample. Resuspend the bacterial pellet by vortexing or mixing by pipetting up and down. Resuspend bacterial cells completely. No clumps should be visible.

3 Lyse bacterial cells

Add **250 µL Buffer A2** to the suspension. (For lysis in tubes: close the culture tube and mix by inverting several times.)

Incubate at **room temperature** for a maximum of **5 min** with moderate shaking (300 rpm).

Note: Do not vortex; doing so will release contaminating chromosomal DNA from the cellular debris into the suspension. Do not allow the lysis reaction to proceed for more than 5 minutes.

4 Neutralize

Add **350 µL Buffer A3** to the suspension. (For lysis in tubes: close the culture tube and mix by inverting several times. For lysis in plates: either mix by pipetting up and down after addition of Buffer A3 or before loading to NucleoSpin® Plasmid Filter Plate.)

Optional: Incubate on ice for 5 min for optimal formation of precipitate.

Prepare the NucleoVac 96 Vacuum Manifold

Prepare manifold for filtration of crude lysates (see page 16):

Insert spacers labeled 'MTP/Multi-96 Plate' notched side up into the grooves located on the short sides of the manifold base. Insert waste container into manifold base. Place the NucleoSpin® R Plasmid Binding Plate (white rings) on top of the spacers.

Insert NucleoSpin® Plasmid Filter Plate (violet rings) into the manifold lid. Close the manifold base with the manifold lid. Close the vacuum manifold's valve.

5 Transfer crude lysates onto the NucleoSpin® Plasmid Filter Plate

Transfer the crude lysates resulting from step 4 carefully and completely into the wells of the NucleoSpin® Plasmid Filter Plate.

Note: Mix the suspension by pipetting up and down the entire volume once before transfer to the NucleoSpin® Plasmid Filter Plate.

6 Clear crude lysate by vacuum filtration

Apply vacuum of **-0.2 to -0.4 bar* (1–5 min)**. If necessary, press down the NucleoSpin® Plasmid Filter Plate slightly until flow through starts. Adjust vacuum to establish a flow rate of 1–2 drops per second.

When the crude lysate has passed the NucleoSpin® Plasmid Filter Plate, release the vacuum.

7 Reassemble vacuum manifold

Remove and discard the NucleoSpin® Plasmid Filter Plate. Open the manifold lid. Remove the NucleoSpin® Plasmid Binding Plate (white rings) with cleared lysates.

Insert the MN Wash Plate on the spacers inside the manifold base (see page 17). Close the manifold base with the manifold lid. Place the Binding Plate on top of the manifold.

8 Bind DNA to silica membrane

Apply vacuum of **-0.2 to -0.4 bar* (1 min)**. If necessary, press down the NucleoSpin® Plasmid Binding Plate slightly until flow through starts. Adjust vacuum to establish a flow rate of 1–2 drops per second.

When the cleared lysate has drained off, release the vacuum.

* Reduction of atmospheric pressure

9 Wash silica membrane

1 st wash (optional)

Add **600 µL Buffer AW** to each well. Apply vacuum of **-0.2 to -0.4 bar* (1 min)**. If necessary, press down the NucleoSpin® Plasmid Binding Plate slightly. Allow the buffer to pass the wells.

Release the vacuum.

Note: This additional wash step is recommended if the bacterial host strain has a high endogenous nuclease activity (e.g., *E. coli* HB 101, BMH 71-18 mutS, JM, or any wild-type strains) or if sequencing results need to be improved.

2nd wash

Add **900 µL Buffer A4** (with ethanol) to each well. Apply vacuum of **-0.2 to -0.4 bar* (1 min)** and allow the buffer to pass the wells.

Release the vacuum.

3rd wash

Repeat the wash step with **900 µL Buffer A4**. Apply vacuum of **-0.2 to -0.4 bar*** (1 min) and allow the buffer to pass the wells.

Release the vacuum.

10 Remove MN Wash Plate

After the final washing step, close the valve, release the vacuum, and remove the NucleoSpin® Plasmid Binding Plate. Remove manifold lid, MN Wash Plate, and waste container from the vacuum manifold.

11 Dry NucleoSpin® Plasmid Binding Plate

Remove any residual wash buffer from the NucleoSpin® Plasmid Binding Plate. If necessary, tap the outlets of the plate onto a clean paper sheet (supplied with the MN Wash Plate) or soft tissue until no drops come out.

Close the manifold base with the manifold lid. Place the NucleoSpin® Binding Plate on top of the manifold.

Apply vacuum of **-0.4 to -0.6 bar*** for **at least 10–15 min** to dry the membrane completely. Run vacuum pump continuously. Typically, the adjusted vacuum is not reached at this step. Achieving and keeping a continuous air-flow in order to evaporate the remaining ethanol from Wash Buffer A4 is of more importance than reaching the precise mentioned atmospheric pressure.

Note: The ethanol in Buffer A4 inhibits enzymatic reactions and has to be completely removed before eluting the DNA.

Finally, release the vacuum.

* Reduction of atmospheric pressure

12 Insert Elution Plate U-bottom

Remove the manifold lid with the NucleoSpin® Plasmid Binding Plate from the vacuum manifold. Insert the Elution Plate on the spacers inside the manifold base. Close the manifold base with the manifold lid. Place the NucleoSpin® Plasmid Binding Plate (white rings) on top of the manifold (see page 17).

For elution into microtiter plates, spacers 'MTP/Multi-96 Plate' are required which are already inserted into the manifold base from the previous steps.

13 Elute plasmid DNA

Elute the DNA by adding 125 µL Buffer AE (5 mM Tris-HCl, pH 8.5; 125 µL is recommended, a volume range of 75–150 µL is possible, see section 2.7) or sterile distilled water (pH 7.5–8.5) to each well of the NucleoSpin® Plasmid Binding Plate.

The elution buffer should be dispensed carefully onto the center of the silica membrane. Incubate the buffer on the membrane for **1–3 minutes** at **room temperature**. Apply vacuum of **-0.4 to -0.6 bar* (1 min)**. If necessary, press down the NucleoSpin® Plasmid Binding Plate slightly and collect the eluted DNA. After the elution buffer has passed the wells, release vacuum.

Remove the Elution Plate U-bottom containing eluted DNA and seal the strips / plate with adhesive cover foil or Cap Strips, respectively, for further storage.

5.2 NucleoSpin® 96 Plasmid – elution of DNA using a centrifuge

Elution of purified DNA in a centrifuge can be performed be necessary when higher concentrations of the final DNA are required for downstream applications. Using a centrifuge allows the dispensed volume to be reduced down to 50–75 µL.

Required hardware:

- For centrifugation, a microtiterplate centrifuge that can accommodate the NucleoSpin® Plasmid Binding Plate stacked on a rack of Tube Strips is required (bucket height: 85 mm). It is also necessary that the centrifuge reaches accelerations of 5,600–6,000 x g.
 - Suitable elution tubes: Rack of Tube Strips have to be ordered separately (see ordering information).
-

1 Stop the method after the final washing step with **Buffer A4**. Remove the NucleoSpin® Plasmid Binding Plate from the manifold's top and tap on a sheet of filter paper to remove residual wash buffer from the outlets.

2 Place the NucleoSpin® Plasmid Binding Plate on top of a MN Square-well Block (not included in the kits, see ordering information) and centrifuge for **10 min** at **maximum speed** (> 4,000 x g, optimal 5,800 x g).

Note: Do not use a microtiter plate as a support for the NucleoSpin® Plasmid Binding Plate. Microtiter plates may crack under centrifugation at > 1,500 x g.

3 Place the NucleoSpin® Plasmid Binding Plate on top of a Rack of Tube Strips. Dispense **Elution Buffer AE** (50–150 µL) directly onto the silica membrane and incubate for **1–3 min** at **room temperature**.

Note: Do not use a microtiter plate as elution plate. Microtiter plates may crack under centrifugation at > 1,500 x g. Alternatively, a 96-well PCR plate can be inserted into the Square-well Block for elution.

4 Centrifuge for **2 min** at **maximum speed** (> 4,000 x g, optimal 5,800 x g) to collect the plasmid DNA.

Remove the Rack of Tube Strips containing eluted DNA and close them with Cap Strips for further storage.

5.3 NucleoSpin® 96 Plasmid – centrifuge processing

This protocol is designed for up to 192 (2 × 96) parallel plasmid DNA preparations from 1.3–5 mL overnight culture.

For use of the NucleoSpin® 96 Plasmid kit in a centrifuge, additional equipment is required:

Protocol step	Suitable consumables, not supplied	REF	Remark
Wash step, collection of cleared lysate	MN Square-well Block	740476	<i>Do not use the (supplied) Elution Plate for elution. This plate may crack when centrifuged > 1,500 rpm.</i>
	Square-well Block	740481	
Elution	Rack of Tube Strips	740477	
	Round-well Block Low	740487	
	Round-well Block	740475	
	Square-well Block	740481	

A microtiterplate centrifuge which is able to accommodate the NucleoSpin® 96 Plasmid Binding Plate stacked on a round or Square-well Block and reaches accelerations of 5,600–6,000 × *g* (bucket height: 85 mm)

All centrifugation steps are performed at room temperature. It is useful to perform 2 × 96 preparations at one time since in all cases the rotor must be balanced.

Add the provided RNase A to Buffer A1, mix, and store at 4 °C. Prepare Buffer A4 according to the user manual.

For information about cultivation of bacteria in the 96-well Culture Plate, please refer to the NucleoSpin® 96 Plasmid user manual.

A repeating pipette and a multichannel pipette facilitate liquid handling during the procedure.

1 Harvest bacterial cells in the Culture Plate

Centrifuge the bacteria cultures (1.5–5 mL LB or up to 2.5 mL 2 x YT or TB) for **10 min** at **1,000 x g**. Discard supernatant.

2 Resuspend bacterial cells

Resuspend pelleted bacterial cells in **250 µL** of **Buffer A1** by pipetting up and down or placing the plate on a suitable microplate shaker. Mark the block for later identification. Ensure that RNase A has been added to Buffer A1.

No cell clumps should be visible after resuspension of the pellets.

3 Lyse bacterial cells

Add **250 µL** of **Buffer A2** to each sample and mix by moderate shaking. The solution becomes viscous and slightly clear when mixed sufficiently.

4 Neutralize

Add **350 µL** of **Buffer A3** to each sample and mix before transferring the lysate to the filter plate with a single aspirate / dispense cycle of 850 µL.

The solutions should become cloudy.

5 Transfer crude lysates onto the NucleoSpin® Plasmid Filter Plate

Place NucleoSpin® Plasmid Filter Plate (purple rings) on top of a new (MN) Square-well Block. Transfer the lysates (from step 4) to the wells of the NucleoSpin® Plasmid Filter Plate. Do not moisten the rims while dispensing samples. Moistened rims may cause cross contamination during centrifugation steps.

6 Clear crude lysates by centrifugation

Load (MN) Square-well Block with NucleoSpin® Plasmid Filter Plate onto the carrier then place in the rotor bucket. Centrifuge at **5,600 x g** for **4 min**.

7 Bind DNA to silica membrane

Place NucleoSpin® Plasmid Binding Plate (transparent rings) on top of new (MN) Square-well Block. Mark the plate for later identification. Transfer the flowthrough from step 6 to the wells of the NucleoSpin® Plasmid Binding Plate. Load (MN) Square-well Block and NucleoSpin® Plasmid Binding Plate onto the carrier then place in the rotor bucket. Centrifuge at **5,600 x g** for **4 min**.

8 Wash silica membrane

1 st wash

Discard the flowthrough from the (MN) Square-well Block. Add **600 µL** of **Buffer AW** to each well. Centrifuge at **5,600 x g** for **4 min**.

This step is necessary to remove trace nuclease activity when using endA strains such as the JM series, HB 101 and its derivatives, or any wild-type strains that have high levels of nuclease activity or high carbohydrate content.

2nd wash

Discard the flowthrough from the (MN) Square-well Block. Add **900 µL of Buffer A4** to each well. Centrifuge at **5,600 x g** for **4 min**.

3rd wash

Repeat wash step with **900 µL of Buffer A4**. Centrifuge again at **5,600 x g** for **1 – 2 min**

9 Dry NucleoSpin® Plasmid Binding Plate

Discard the flowthrough from the (MN) Square-well Block. Centrifuge at **5,600 x g** for **10 – 15 min** in order to dry the membrane. Alternatively incubate NucleoSpin® Plasmid Binding Plate for 10 min at 70 °C in a suitable incubator.

10 Elute plasmid DNA

Place NucleoSpin® Plasmid Binding Plate on new deep-well block (e.g., (MN) Square-well Block). Dispense **50 – 75 µL Buffer AE** to each well of the plate. Incubate for 1–3 min at RT. Centrifuge at **5,600 x g** for **4 min** to collect DNA. *Note: Do not use (supplied) Elution Plate for elution. This plate may crack when centrifuged > 1,500 rpm.*

6 Appendix

6.1 Troubleshooting

Problem	Possible cause and suggestions
Incomplete lysis of bacterial cells	<i>Cell pellet not properly resuspended</i>
	<ul style="list-style-type: none"> It is essential that the cell pellet is completely resuspended prior to lysis. No cell clumps should be visible before addition of Lysis Buffer A2. If necessary, increase number of mixing cycles or duration of shaking.
	<i>SDS in Buffer A2 precipitated</i>
	<ul style="list-style-type: none"> SDS in Buffer A2 may precipitate upon storage. If this happens, a white precipitate is visible at the bottom of the bottle. Incubate Buffer A2 at 30–40 °C for 5 min and mix well before use.
	<i>Too many bacterial cells used</i>
	<ul style="list-style-type: none"> Usage of LB as the growth medium is recommended. When using rich media like TB, cultures reach very high cell densities. Reduce culture volume to 1.0–1.5 mL.
	<i>No or not enough antibiotic used during cultivation</i>
	<ul style="list-style-type: none"> Cells harboring the plasmid of interest may become overgrown by non-transformed cells. Add appropriate amounts of freshly prepared stock solutions of antibiotic to all media.
	<i>Overgrown bacterial cultures</i>
Poor plasmid yield	<ul style="list-style-type: none"> See suggestions in section 2.6 'Growth of bacterial cultures'.
	<i>High-copy number plasmid was not used</i>
	<ul style="list-style-type: none"> Use high-copy number plasmid.
	<i>Incomplete lysis of bacterial cells</i>
	<ul style="list-style-type: none"> See 'Possible cause and suggestions' above.
	<i>No ethanol was added to Buffer A4 Concentrate, ethanol evaporated</i>
	<ul style="list-style-type: none"> Add indicated volume of ethanol to Buffer A4 Concentrate and mix. Keep bottle tightly closed to prevent evaporation of ethanol.
	<i>Elution conditions are not optimal</i>
	<ul style="list-style-type: none"> If possible, use a slightly alkaline elution buffer like Buffer AE (5 mM Tris-HCl, pH 8.5). When using nuclease-free water for elution, make sure the pH value is within the range of pH 8.0–8.5. Elution efficiencies drop drastically at pH < 7.

Problem	Possible cause and suggestions
----------------	---------------------------------------

Contamina- tion with chromo- somal DNA	<i>Excessive mixing steps</i>
	<ul style="list-style-type: none">• Reduce number of mixing cycles, reduce shaker action after addition of Lysis Buffer A2 and Neutralization Buffer A3 or before transfer of crude lysate to the NucleoSpin® Plasmid Filter Strips. Mixing will cause shearing of chromosomal DNA, leading to a co-purification during the preparation of plasmid DNA.
	<i>Culture volume was too high</i>
	<ul style="list-style-type: none">• Reduce culture volume if lysate is too viscous for gentle and complete mixing.
	<i>Bacterial culture overgrown</i>
RNA in the eluate	<ul style="list-style-type: none">• Overgrown bacterial cultures contain lysed cells and degraded DNA. See suggestions in section 2.6 'Growth of bacterial cultures'.
	<i>Lysis was too long</i>
	<ul style="list-style-type: none">• Lysis step must not exceed 5 min.
	<i>Tips</i>
	<ul style="list-style-type: none">• Use wide bore disposable tips for transfer of crude lysate to the NucleoSpin® Plasmid Filter Plate to prevent shearing of chromosomal DNA.
	<i>RNA was not degraded completely</i>
	<ul style="list-style-type: none">• Ensure that RNase A was added to Buffer A1 before use.• Reduce culture volume if necessary.

Problem **Possible cause and suggestions**

Suboptimal performance of plasmid DNA in sequencing reactions, problems with downstream applications	<p><i>Carry-over of ethanol, inhibition of downstream analysis, or problems with sample loading onto agarose</i></p> <ul style="list-style-type: none"> • Be sure to remove all of ethanolic Buffer A4 after the final washing step. Dry the NucleoSpin® Plasmid Binding Plate for at least 10 min with maximum vacuum. <p><i>Elution of plasmid DNA with TE buffer</i></p> <ul style="list-style-type: none"> • EDTA may inhibit enzymatic reactions like DNA sequencing. Repurify the plasmid DNA and elute with Buffer AE or nuclease-free water. Alternatively, the plasmid DNA may be precipitated with ethanol, and redissolved in Buffer AE or nuclease-free water. <p><i>E.coli strains with high endogenous-nuclease levels are used as host</i></p> <ul style="list-style-type: none"> • Perform the washing step with Buffer AW before washing with ethanolic Buffer A4. <p><i>Not enough DNA used for sequencing reactions</i></p> <ul style="list-style-type: none"> • Quantitate DNA by agarose gel electrophoresis before setting up sequencing reactions.
--	---

6.2 Ordering information

Product	REF	Pack of
NucleoSpin® 96 Plasmid	740625.1	1 × 96 preps
	740625.4	4 × 96 preps
	740625.24	24 × 96 preps
NucleoSpin® 96 Plasmid Core Kit	740616.4	4 × 96 preps
	740616.24	24 × 96 preps
NucleoSpin® 8 Plasmid	740621	12 × 8 preps
	740621.5	60 × 8 preps
NucleoSpin® 8 Plasmid Core Kit	740461.4	48 × 8 preps
Buffer A1 (without RNase A)	740911.1	1 L
Buffer A2	740912.1	1 L
Buffer A3	740913.1	1 L
Buffer A4 Concentrate (for 1 L Buffer A4)	740914	200 mL
Buffer AW	740916.1	1 L

Product	REF	Pack of
Buffer AE	740917.1	1 L
RNase A (lyophilized)	740505	100 mg
NucleoVac 96 Vacuum Manifold	740681	1
NucleoVac Vacuum Regulator	740641	1
MN Positive Pressure Frame	740474	1
Round-well Block with Cap Strips	740475 740475.24	4 sets 24 sets
Rack of Tube Strips (1 set consists of 1 rack, 12 strips with 8 tubes each, and 12 Cap Strips)	740477 740477.24	4 sets 24 sets
Cap Strips	740478 740478.24	48 288
MN Square-well Block	740476 740476.24	4 24
MN Wash Plate	740479 740479.24	4 24
Culture Plate (with Gas-permeable Foil)	740488 740488.24	4 sets 24 sets
Elution Plate U-bottom (with Self adhering Foil)	740486.24	24 sets
Gas-permeable Foil	740675	50
Self adhering Foil	740676	50

Visit www.mn-net.com for more detailed product information.

6.3 Product use restriction / warranty

All MACHEREY-NAGEL products are designed for their intended use only. They are not intended to be used for any other purpose. The description of the intended use of the products can be found in the original MACHEREY-NAGEL product leaflets. Before using our products, please observe the instructions for use and the safety instructions from the respective Material Safety Data Sheet of the product.

This MACHEREY-NAGEL product is carrying documentation stating specifications and other technical information. MACHEREY-NAGEL warrants to meet the stated specifications. The provided warranty is limited to the data specifications and descriptions as given in the original MACHEREY-NAGEL literature. No other statements or representations, written or oral, by MACHEREY-NAGEL's employees, agents or representatives, except written

statements signed by a duly authorized officer of MACHEREY-NAGEL are authorized. They should not be relied upon by the customer and are not a part of a contract of sale or of this warranty.

Liability for all possible damages that occur in any connection with our products is limited to the utmost minimum as stated in the general business terms and conditions of MACHEREY-NAGEL in their latest edition which can be taken from the company's website. MACHEREY-NAGEL does not assume any further warranty.

Products and their application are subject to change. Therefore, please contact our Technical Service Team for the latest information on MACHEREY-NAGEL products. You may also contact your local distributor for general scientific information. Descriptions in MACHEREY-NAGEL literature are provided for informational purposes only.

Last updated: 08/2022, Rev. 04

Please contact:

MACHEREY-NAGEL GmbH & Co. KG

Tel.: +49 24 21 969-333 support@mn-net.com

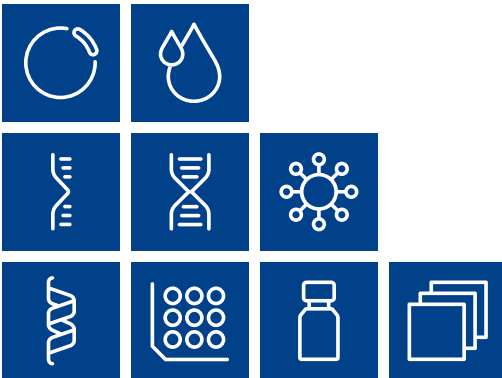

Plasmid DNA

Clean up

RNA

DNA

Viral RNA and DNA

Protein

High throughput

Accessories

Auxiliary tools

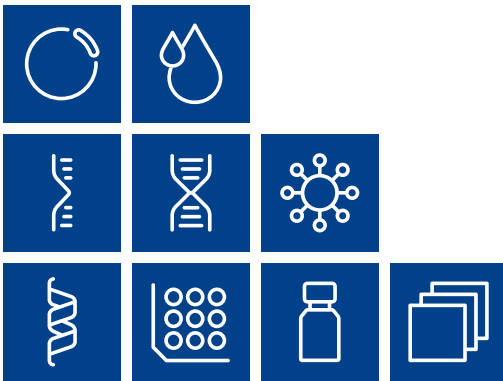

A039503/0xxX

www.mn-net.com

MACHEREY-NAGEL



 TÜVRheinland CERTIFIED	Management System EN ISO 13485:2016 ISO 9001:2015	
	www.tuv.com ID 0000056401	

MACHEREY-NAGEL GmbH & Co. KG · Valenciener Str. 11 · 52355 Düren · Germany

DE +49 24 21 969-0 info@mn-net.com

CH +41 62 388 55 00 sales-ch@mn-net.com

FR +33 388 68 22 68 sales-fr@mn-net.com

US +1 888 321 62 24 sales-us@mn-net.com