

MACHEREY-NAGEL

# User manual

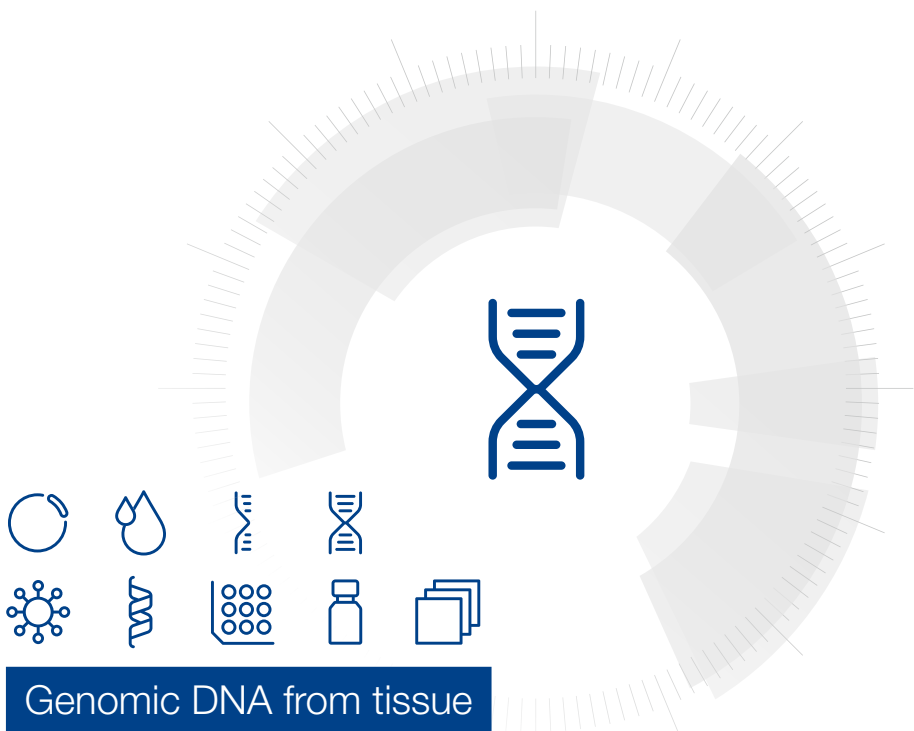

- NucleoSpin® 96 Tissue
- NucleoSpin® 96 Tissue Core Kit

November 2023 / Rev. 11

## Contact MN

### Germany and international

MACHEREY-NAGEL GmbH & Co. KG  
Valenciener Str. 11 · 52355 Düren · Germany  
Tel.: +49 24 21 969-0  
Toll-free: 0800 26 16 000 (Germany only)  
E-mail: [info@mn-net.com](mailto:info@mn-net.com)

### Technical Support Bioanalysis

Tel.: +49 24 21 969-333  
E-mail: [support@mn-net.com](mailto:support@mn-net.com)

### USA

MACHEREY-NAGEL Inc.  
924 Marcon Blvd. · Suite 102 · Allentown PA, 18109 · USA  
Toll-free: 888 321 6224 (MACH)  
E-mail: [sales-us@mn-net.com](mailto:sales-us@mn-net.com)

### France

MACHEREY-NAGEL SAS  
1, rue Gutenberg – BP135 · 67720 Hoerdt Cedex · France  
Tel.: +33 388 68 22 68  
E-mail: [sales-fr@mn-net.com](mailto:sales-fr@mn-net.com)

MACHEREY-NAGEL SAS (Société par Actions Simplifiée) au capital de 186600 €  
Siret 379 859 531 00020 · RCS Strasbourg B379859531 · N° intracommunautaire FR04 379 859 531

### Switzerland

MACHEREY-NAGEL AG  
Hirsackerstr. 7 · 4702 Oensingen · Switzerland  
Tel.: +41 62 388 55 00  
E-mail: [sales-ch@mn-net.com](mailto:sales-ch@mn-net.com)

---

## Table of contents

1 Components	4
1.1 Kit contents	4
1.2 Reagents to be supplied by user	5
1.3 About this user manual	5
2 Product description	6
2.1 The basic principle	6
2.2 Kit specifications	6
2.3 Required hardware	7
2.4 Accessories supplied for use of the NucleoSpin® 96 Tissue Core Kit	8
2.5 Automated processing on robotic platforms	10
2.6 Elution procedures	10
3 Storage conditions and preparation of working solutions	12
4 Safety instructions	13
4.1 Disposal	13
5 Protocols	14
5.1 NucleoSpin® 96 Tissue – centrifuge processing	14
5.2 NucleoSpin® 96 Tissue – vacuum processing	18
5.3 NucleoSpin® 96 Tissue – purification of DNA from up to $5 \times 10^6$ cultured cells	24
6 Appendix	25
6.1 Troubleshooting	25
6.2 Ordering information	27
6.3 Product use restriction/warranty	28

# 1 Components

## 1.1 Kit contents

NucleoSpin® 96 Tissue			
REF	2 × 96 preps 740741.2	4 × 96 preps 740741.4	24 × 96 preps 740741.24 <sup>1</sup>
Lysis Buffer T1	50 mL	100 mL	6 × 100 mL
Binding Buffer BQ1	50 mL	100 mL	6 × 100 mL
Wash Buffer B5 (Concentrate) <sup>2</sup>	100 mL	2 × 100 mL	12 × 100 mL
Wash Buffer BW	125 mL	2 × 125 mL	12 × 125 mL
Elution Buffer BE <sup>3</sup>	60 mL	125 mL	6 × 125 mL
Proteinase K (lyophilized) <sup>2</sup>	2 × 75 mg	4 × 75 mg	24 × 75 mg
Proteinase Buffer PB	8 mL	15 mL	6 × 15 mL
NucleoSpin® Tissue Binding Plates (green rings)	2	4	24
Round-well Blocks <sup>4</sup>	2	4	24
MN Square-well Blocks	2	4	24
MN Wash Plates <sup>5</sup>	2	4	24
Rack of Tube Strips <sup>6</sup>	2	4	24
Cap Strips	24	48	288
Self adhering PE Foil	5	10	60
User manual	1	1	6

<sup>1</sup> The kit for 24 × 96 preparations (REF 740741.24) consists of 6 × REF 740741.4.

<sup>2</sup> For preparation of working solutions and storage conditions, see section 3.

<sup>3</sup> Elution Buffer BE: 5 mM Tris/HCl, pH 8.5

<sup>4</sup> Including 12 Cap Strips for each block

<sup>5</sup> For use with vacuum only

<sup>6</sup> Sets of 1 rack, 12 strips with 8 tubes each, including Cap Strips

**Kit contents (continued)**

<b>NucleoSpin® 96 Tissue Core Kit</b>	
<b>REF</b>	<b>4 × 96 preps 740454.4</b>
Lysis Buffer T1	100 mL
Binding Buffer BQ1	100 mL
Wash Buffer B5 (Concentrate) <sup>1</sup>	2 × 100 mL
Wash Buffer BW	2 × 125 mL
Elution Buffer BE <sup>2</sup>	125 mL
Proteinase K (lyophilized) <sup>1</sup>	4 × 75 mg
Proteinase Buffer PB	15 mL
NucleoSpin® Tissue Binding Plates (green rings)	4
User manual	1

**1.2 Reagents to be supplied by user**

- 96–100 % ethanol (for preparation of working solutions; see section 3)

For more detailed information regarding special hardware required for centrifuge or vacuum processing, please see section 2.3.

For recommended accessories for use of the flexible **NucleoSpin® 96 Tissue Core Kit** (reduced kit composition; REF 740454.4), please see section 2.4.

**1.3 About this user manual**

It is recommended to read the instructions of this user manual carefully before use. All technical literature is available on the internet at [www.mn-net.com](http://www.mn-net.com).

Please contact Technical Service regarding information about changes of the current user manual compared to previous revisions.

<sup>1</sup> For preparation of working solutions and storage conditions, see section 3.

<sup>2</sup> Elution Buffer BE: 5 mM Tris/HCl, pH 8.5

## 2 Product description

### 2.1 The basic principle

The **NucleoSpin® 96 Tissue** kit is designed for the efficient isolation of high molecular weight genomic DNA from tissue samples or cells. With the **NucleoSpin® 96 Tissue** procedure, sample lysis is achieved by incubation of the samples in a solution containing SDS and Proteinase K. Appropriate conditions for binding of DNA to the silica membrane in the NucleoSpin® Tissue Binding Plate are created by addition of large amounts of chaotropic salt and ethanol to the lysate. The binding process is reversible and specific to nucleic acids. While DNA is kept on the silica membrane, contaminations are removed by washing with two different wash buffers. Pure genomic DNA is finally eluted under low ionic strength conditions in a slightly alkaline elution buffer.

### 2.2 Kit specifications

- **NucleoSpin® 96 Tissue** is designed for the rapid preparation of highly pure genomic DNA from tissue, for example, mouse and rat tails, organ tissue, or animal or bacterial cells. The purified DNA can be used directly as template for PCR, blotting, or any kind of enzymatic reactions.
- This kit provides reagents and consumables for purification of up to 40 µg (average 20 µg) of pure genomic DNA from up to 20 mg tissue samples with an  $A_{260}/A_{280}$  ratio between 1.8 and 1.9 and a typical concentration of 100–200 ng/µL.
- From up to two 0.5 cm long mouse tail tip section (age of mice: 4–6 weeks), up to 35 µg of pure genomic DNA can be prepared (typical yields: 15–25 µg).
- **NucleoSpin® 96 Tissue** can be processed by vacuum, positive pressure or in a centrifuge. The kit allow easy automation on common liquid handling instruments.
- The **NucleoSpin® 96 Tissue** kits allow for the purification of multiples of 96 samples. The kits are supplied with accessory plates for highest convenience. The kits are designed for manual or automated use in a centrifuge or for use with a vacuum manifold. The **NucleoSpin® 96 Tissue Core Kit** provides the buffers, Proteinase K and NucleoSpin® Tissue Binding Plate only. Accessory components (e.g., lysis plates, elution plates) are not provided with the core kit but can be individually selected from a variety of suitable accessories (see section 2.4 for further information). This allows highest flexibility for the user.

**Table 1: Kit specifications at a glance**

Parameter	NucleoSpin® 96 Tissue
Format	96-well plates
Processing	Manual and automated, vacuum, positive pressure or centrifugation
Sample material	Up to 20 mg tissue, up to 10 <sup>6</sup> cultured cells, bacteria
Typical yield	15–25 µg
A <sub>260</sub> /A <sub>280</sub>	1.8–1.9
Elution volume	100–200 µL
Preparation time	60 min/plate (excl. lysis)
Binding capacity	40 µg
Use	For research use only

## 2.3 Required hardware

**NucleoSpin® 96 Tissue** can be processed under vacuum, positive pressure or with centrifugation. Certain hardware for processing is required.

### *Centrifugation*

For centrifugation, a microtiterplate centrifuge is required. This centrifuge must be able to accommodate the NucleoSpin® Tissue Binding Plate stacked on a Round- or Square-well Block and reach accelerations of 5,600–6,000 x g is required (bucket height: 85 mm).

Regarding waste collection, suitable consumables (e.g., MN Square-well Blocks) are necessary and they are not included in the kit. For the most convenient handling, without the need of emptying and reusing the MN Square-well Blocks, we recommend using six MN Square-well Blocks if two 96-well plates are processed at once (see ordering information, section 6.2). Alternatively, it is possible to empty the MN Square-well Blocks after every centrifugation step, reducing the amount of MN Square-well Blocks needed.

### *Vacuum processing*

The **NucleoSpin® 96 Tissue** kit can be used with the NucleoVac 96 Vacuum Manifold (see ordering information, section 6.2). When using **NucleoSpin® 96 Tissue** with less than 96 samples, Self adhering PE Foil (see ordering information, section 6.2) should be used in order to close and protect non-used wells of the NucleoSpin® Tissue Binding Plate and thus guarantee proper vacuum.

Establish a reliable vacuum source for the NucleoVac 96 Vacuum Manifold. The manifold may be used with a vacuum pump, house vacuum, or water aspirator. We recommend a vacuum of -0.2 to -0.4 bar (reduction of atmospheric pressure). The use of the NucleoVac Vacuum Regulator (see ordering information, section 6.2) is recommended. Alternatively,

adjust the vacuum so that during the purification the sample flows through the column with a rate of 1–2 drops per second. Depending on the amount of sample being used, the vacuum times may need to be increased for complete filtration.

Additionally, a suitable centrifuge for sample preparation steps may be required.



For general consumables and equipment needed, please see section 1.2.

## 2.4 Accessories supplied for use of the NucleoSpin® 96 Tissue Core Kit

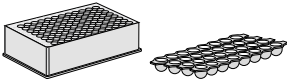

The **NucleoSpin® 96 Tissue Core Kit** provides buffers, Proteinase K, and NucleoSpin® Tissue Binding Plates. Accessory plates (e.g., lysis plates, elution plates) are not provided with the core kit. The reduced kit composition along with a variety of separately available accessories, allow optimal adjustment of the kit to individual user needs. The user can select additional consumables according to his/her requirements for highest flexibility.

For use of **NucleoSpin® 96 Tissue Core Kit**, follow the standard protocols (see section 5.1 and 5.2).

Recommended accessories for use of the **NucleoSpin® 96 Tissue Core Kit** are available from MACHEREY-NAGEL (see ordering information, section 6.2).

Protocol step	Suitable consumables, not supplied with the core kits	Remarks
2. Lyse samples	4 x Round-well Block with Cap Strips per 4 x 96 preps    or 4 x Rack of Tube Strips with Cap Strips per 4 x 96 preps  	For sample lysis.

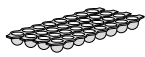
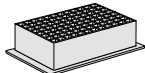
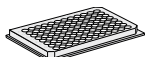
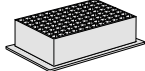

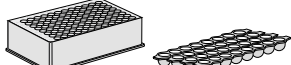
Protocol step	Suitable consumables, not supplied with the core kits	Remarks
3. Adjust binding conditions	<p>48 x Cap Strips per 4 x 96 preps</p>  <p>4 x MN Square-well Block per 4 x 96 preps</p> 	<p>When using Round-well Block or Tube Strips for lysis, new Cap Strips are required for sealing of wells after adding Buffer BQ1 and ethanol.</p> <p>Recommended for automated processing only</p>
5. Bind DNA to the membrane	<p>4 x MN Wash Plate per 4 x 96 preps</p> 	<p>MN Wash Plate minimizes the risk of cross contamination (vacuum processing only).</p>
	<p>2 x MN Square-well Block</p> 	<p>For waste collection during centrifugation (reusable)</p>
8. Elute DNA	<p>4x Rack of Tube Strips with Cap Strips per 4 x 96 preps</p>  <p>or 4 x Round-well Block with Cap Strips per 4 x 96 preps</p> 	

## 2.5 Automated processing on robotic platforms

**NucleoSpin® 96 Tissue** can be used fully automated on many common laboratory workstations. For the availability of scripts and general considerations about adapting **NucleoSpin® 96 Tissue** on a certain workstation, please contact MN. Full processing under vacuum enables complete automation without the need for centrifugation steps for drying of the binding membrane or for elution. However, a final elution step by centrifugation is recommended in order to achieve higher concentrated eluted DNA.

The risk of cross-contamination is reduced by optimized vacuum settings during the elution step and by the improved shape of the outlets of the NucleoSpin® Tissue Binding Plate.

Drying of the NucleoSpin® Tissue Binding Plates under vacuum is sufficient because the bottom of the plate is protected by the MN Wash Plate during the washing steps. As a result, it is recommended to integrate the MN Wash Plate into the automated procedure to protect against these wash buffer residues. The MN Frame (see ordering information) can be used to position the disposable MN Wash Plate inside the vacuum chamber. This also reduces the risk of cross-contamination, as common metal adaptors tend to get contaminated by gDNA. Thorough cleaning of the vacuum chamber is recommended after each run to prevent DNA-containing aerosols from forming.

Visit MN online at [www.mn-net.com](http://www.mn-net.com) or contact your local MACHEREY-NAGEL distributor for technical support regarding hardware, software, setup instructions, and selection of the protocol. Several application notes of the **NucleoSpin® 96 Tissue** kit on various liquid handling instruments can also be found at [www.mn-net.com](http://www.mn-net.com) at Bioanalysis / Literature.

## 2.6 Elution procedures

It is possible to adjust the elution method and the volume of the elution buffer to the subsequent application of interest. In addition, to the standard method described in the protocols (recovery rate about 70–90%) there are several modifications possible. Use elution buffer preheated at 70 °C for one of the following procedures:

- **High yield:** Perform two elution steps with the volume indicated in the individual protocol. About 90–100% of bound nucleic acids can be eluted.
- **High concentration:** Perform one elution step with only 60% of the volume indicated in the individual protocol. Concentration of DNA will be about 30% higher than with the standard elution procedure. Maximum yield of bound nucleic acids is about 80%.
- **High yield and high concentration:** Apply half the volume of elution buffer as indicated in the individual protocol, incubate for 3 min and centrifuge. Apply a second aliquot of elution buffer, incubate and centrifuge again. Thus, about 85–100% of bound nucleic acids are eluted in the standard elution volume at a high concentration.
- **Convenient elution:** For convenience, elution buffer of ambient temperature may be used. This will result in a slightly lower yield (approximately 20%) compared to elution with heated elution buffer.

Elution may also be performed with Tris-EDTA-buffer (TE) of pH equal or higher than 8. This will increase DNA stability during long term or multi-use storage at 4 °C (or ambient temperature) by inhibiting omnipresent DNases. However, EDTA interferes, depending on the final concentration, with certain downstream applications.

For optimal performance of isolated DNA in downstream applications, we recommend eluting with the supplied elution buffer and storing it, especially long term, at - 20 °C. Several freeze-thaw cycles will not interfere with most downstream applications.

Performance of long-range PCR (e.g., > 10 kb) or the detection limit of trace amount of DNA species, may be reduced after multiple freeze-thaw cycles or prolonged storage of eluted DNA at 4 °C or room temperature. This is due to shearing of DNA or adsorption to surfaces.

Due to the dead volume of the silica membrane, please note that the difference between the dispensed elution buffer volume and the recovered elution buffer volume containing genomic DNA is approximately 20 µL (recovered elution volume = dispensed elution volume - 20 µL).

### 3 Storage conditions and preparation of working solutions

**Attention:** Buffer BQ1 and BW contain chaotropic salts. Wear gloves and goggles!

**CAUTION:** Buffers BQ1 and BW contain guanidine hydrochloride which can form highly reactive compounds when combined with bleach (sodium hypochlorite). DO NOT add bleach or acidic solutions directly to the sample-preparation waste.

Storage conditions:

- All components of the **NucleoSpin® 96 Tissue** kits should be stored at room temperature (15–25 °C) and are stable until: see package label. Storage at lower temperatures may cause precipitation of salts. If a salt precipitation is observed, incubate the bottle at 30–40 °C for some minutes and mix well until all of the precipitate is redissolved. The performance of the kits is not affected by the salt precipitates.

Before starting any **NucleoSpin® 96 Tissue** protocol, prepare the following:

- Wash Buffer B5:** Add the indicated volume of ethanol (96–100 %) to **Buffer B5 Concentrate** before use. Mark the label of the bottle to indicate that ethanol was added. Store **Wash Buffer B5** at room temperature for up to one year.
- Before first use of the kit, add the indicated volume of **Proteinase Buffer PB** to lyophilized **Proteinase K**. Proteinase K solution is stable at -20 °C for up to 6 months.

NucleoSpin® 96 Tissue			
REF	2 × 96 preps 740741.2	4 × 96 preps 740741.4	24 × 96 preps 740741.24
Wash Buffer B5 (Concentrate)	100 mL Add 400 mL ethanol	2 × 100 mL Add 400 mL ethanol to each bottle	12 × 100 mL Add 400 mL ethanol to each bottle
Proteinase K (lyophilized)	2 × 75 mg Add 2.6 mL Proteinase Buffer PB to each vial	4 × 75 mg Add 2.6 mL Proteinase Buffer PB to each vial	24 × 75 mg Add 2.6 mL Proteinase Buffer PB to each vial

NucleoSpin® 96 Tissue Core Kit	
REF	4 × 96 preps 740454.4
Wash Buffer B5 (Concentrate)	2 × 100 mL Add 400 mL ethanol to each bottle
Proteinase K (lyophilized)	4 × 75 mg Add 2.6 mL Proteinase Buffer to each vial

## 4 Safety instructions

When working with the **NucleoSpin® 96 Tissue** and **NucleoSpin® 96 Tissue Core** kit wear suitable protective clothing (e.g., lab coat, disposable gloves, and protective goggles). For more information consult the appropriate Material Safety Data Sheets (MSDS available online at [www.mn-net.com/msds](http://www.mn-net.com/msds)).



Caution: Guanidine hydrochloride in buffer BQ1 and buffer BW can form highly reactive compounds when combined with bleach! Thus, do not add bleach or acidic solutions directly to the sample preparation waste.

The waste generated with the **NucleoSpin® 96 Tissue** and **NucleoSpin® 96 Tissue Core** kit has not been tested for residual infectious material. A contamination of the liquid waste with residual infectious material is highly unlikely due to strong denaturing lysis buffer and Proteinase K treatment but it cannot be excluded completely. Therefore, liquid waste must be considered infectious and should be handled and discarded according local safety regulations.

### 4.1 Disposal

Dispose hazardous, infectious or biologically contaminated materials in a safe and acceptable manner and in accordance with all local and regulatory requirements.

## 5 Protocols

### 5.1 NucleoSpin® 96 Tissue – centrifuge processing

- For hardware requirements, refer to section 2.3.
- For detailed information on each step, see page 15.
- For use of the NucleoSpin® 96 Tissue Core Kit (REF 740454.4), refer to section 2.4 regarding recommended accessories.

#### Before starting the preparation:

- Check if Buffer B5 and Proteinase K were prepared according to section 3.
- Set incubator or oven to 56 °C.
- Preheat Elution Buffer BE to 70 °C.

#### Protocol at a glance

1	<b>Prepare</b> samples	2 × 0.5 cm mouse tail or up to 20 mg tissue, 10 <sup>6</sup> cultured cells, or bacteria
2	<b>Lyse</b> samples	180 µL T1 25 µL Proteinase K Mix 56 °C, ≥ 6 h
3	<b>Adjust</b> DNA binding conditions	200 µL BQ1 200 µL ethanol (96 – 100 %) Mix
4	<b>Transfer</b> lysates to NucleoSpin® Tissue Binding Plate	
5	<b>Bind</b> DNA to silica membrane of the NucleoSpin® Tissue Binding Plate	5,600 × g, 10 min

<b>6</b>	<b>Wash</b> silica membrane	<b>500 µL BW</b>  <b>5,600 x g,</b> <b>2 min</b>   <b>700 µL B5</b>  <b>5,600 x g,</b> <b>4 min</b>
<b>7</b>	<b>Dry</b> silica membrane	<b>70 °C, 10 min</b>
<b>8</b>	<b>Elute</b> DNA	<b>100 µL BE (70 °C)</b>  <b>5,600 x g,</b> <b>2 min</b>

**Optional: Repeat elution step once.**

---

## Detailed protocol

- For hardware requirements, refer to section 2.3.
- For use of the NucleoSpin® 96 Tissue Core Kit (REF 740454.4), refer to section 2.4 regarding recommended accessories.

### Before starting the preparation:

- Check if Buffer B5 and Proteinase K were prepared according to section 3.
- Set incubator or oven to 56 °C.
- Preheat Elution Buffer BE to 70 °C.

### **1** Prepare samples

For each preparation, cut up to two 0.5 cm pieces (20 mg) of mouse tail into appropriate lysis tubes or plates. If preparing DNA from rat tails, one 0.5 cm piece is sufficient. Tissue samples should not exceed 20 mg, cultured cells and bacteria should not exceed 10<sup>6</sup> cells.

---

## 2 Lyse samples

Prepare a Proteinase K working solution: For each sample, mix **25 µL Proteinase K** with **180 µL Buffer T1** and vortex. Transfer 200 µL of the resulting solution to each well of the Round-well Block containing the samples. Close the wells with Cap Strips. Mix by vigorous shaking for 10–15 s. Spin briefly (15 s; 1,500 x g) to collect any sample at the bottom of the wells.

*The samples must be submerged in the solution. Never prepare the Proteinase K working solution more than 15 min before addition to the samples. Proteinase K tends to self digestion when incubated in Buffer T1 without substrate.*

Incubate the Round-well Block containing the samples at **56 °C** for **at least 6 h** (for mammalian cells reduce incubation to 10 min, bacterial cells may require prelysis with, e.g., lysozyme) or overnight until the samples are completely lysed. For optimal lysis, mix occasionally during incubation. Place a weight on top of the Round-well Block in order to prevent the Cap Strips from popping off occasionally.

*After lysis, set the incubator to 70 °C for the membrane drying step.*

Centrifuge the Round-well Block (15 s; 1,500 x g) to collect any condensate from the Cap Strips. Remove Cap Strips.

*Residual hair and / or bones in the lysate can be removed by centrifugation (2 min; 5,600–6,000 x g) and transfer of the supernatant to a new Round-well Block (not supplied with the kit).*

---

## 3 Adjust DNA binding conditions

Add **200 µL Buffer BQ1** and **200 µL 96–100 % ethanol** to each sample. Again, take care not to moisten the rims of the individual wells while dispensing the buffer. Close the individual wells with new Cap Strips (supplied). Mix by vigorous shaking for 10–15 s. Spin briefly (10 s; 1,500 x g) to collect any sample from the Cap Strips.

*Ethanol and Buffer BQ1 can be premixed before addition to the samples, if the mixture is to be used during the next 3 months. Never centrifuge at higher g-forces or for longer periods as DNA will precipitate.*

Place a NucleoSpin® Tissue Binding Plate on a MN Square-well Block.

*If using more than one plate, label the plates for later identification. The use of a second plate placed on a MN Square-well Block avoids the need to balance the centrifuge.*

---



#### 4 Transfer lysates

Remove the first Cap Strip and transfer the lysates resulting from step 2 carefully from the Round-well Block into the wells of the NucleoSpin® Tissue Binding Plate. Continue with the next eight samples. Do not moisten the rims of the individual wells while dispensing the samples – moistened rims may cause cross contamination during centrifugation. After transfer, seal the openings of the plate with Self adhering PE Foil.

*For transfer of the lysate from the Round-well Block to the NucleoSpin® Tissue Binding Plate, we recommend use of an electronic eight-channel pipetting device with extra long tips capable of holding more than 650 µL.*

---

#### 5 Bind DNA to silica membrane

Place the MN Square-well Blocks with NucleoSpin® Tissue Binding Plates onto the centrifuge carriers and insert them into the rotor buckets. Centrifuge at **5,600–6,000 x g** for **10 min**.

*Typically, the lysates will have passed through the silica membrane within a few minutes. The centrifugation process can be extended to 20 min, if the lysates have not passed completely.*

---

#### 6 Wash silica membrane

##### **1<sup>st</sup> wash**

Remove the Self adhering PE Foil and add **500 µL Buffer BW** to each well of the NucleoSpin® Tissue Binding Plate. Seal the plate with a new Self adhering PE Foil and centrifuge again at **5,600–6,000 x g** for **2 min**.

##### **2<sup>nd</sup> wash**

Remove the Self adhering PE Foil and add **700 µL Buffer B5** to each well of the NucleoSpin® Tissue Binding Plate. Re-use the Self adhering PE Foil to seal the plate and centrifuge again at **5,600–6,000 x g** for **4 min**.

*During this step, as much ethanolic Buffer B5 as possible is removed by centrifugation.*

---

#### 7 Dry silica membrane

Remove the Self adhering PE Foil and place the NucleoSpin® Tissue Binding Plate on an opened Rack of Tube Strips. Place it in an incubator for **10 min** at **70 °C** to evaporate residual ethanol.

*Removal of ethanol by evaporation at 70 °C is more effective than prolonged centrifugation.*

*Note: The ethanol in Buffer B5 may inhibit enzymatic reactions and should be removed completely before eluting DNA.*

---

## 8 Elute DNA

Dispense **100 µL preheated Buffer BE (70 °C)** to each well of the NucleoSpin® Tissue Binding Plate. Dispense the buffer directly onto the membrane. Incubate at room temperature for **1 min**. Centrifuge at **5,600–6,000 x g** for **2 min**. Repeat elution step once. Remove the NucleoSpin® Tissue Binding Plate from the Rack of Tube Strips by lifting the plate at one side carefully as the Tube Strips may stick to the outlets of the NucleoSpin® Tissue Binding Plate. For alternative elution procedures see section 2.3.

*If elution in small volume tubes is desired, place a 96 PCR plate (not supplied) on top of a Round-well Block or a Rack of Tube Strips and elute into the PCR plate.*

## 5.2 NucleoSpin® 96 Tissue – vacuum processing

- For hardware requirements, refer to section 2.3.
- For detailed information regarding the vacuum manifold setup, see page 20.
- For detailed information on each step, see page 21.
- For use of the NucleoSpin® 96 Tissue **Core Kit** (REF 740454.4), refer to section 2.4 regarding recommended accessories.

### Before starting the preparation:

- Check if Buffer B5 and Proteinase K were prepared according to section 3.
- Set incubator or oven to 56 °C.
- Preheat Elution Buffer BE to 70 °C.

## Protocol at a glance

<b>1</b>	<b>Prepare samples</b>	<b>2 x 0.5 cm mouse tail or up to 20 mg tissue, 10<sup>6</sup> cultured cells, or bacteria</b>
<b>2</b>	<b>Lyse samples</b>	<b>180 µL T1 25 µL Proteinase K Mix 56 °C, ≥ 6 h</b>
<b>3</b>	<b>Adjust DNA binding conditions</b>	<b>200 µL BQ1 200 µL ethanol (96–100 %) Mix Prepare the NucleoVac 96 Vacuum Manifold</b>

<b>4</b>	<b>Transfer</b> lysates to NucleoSpin® Tissue Binding Plate	
<b>5</b>	<b>Bind</b> DNA to silica membrane of the NucleoSpin® Tissue Binding Plate	<b>-0.2 bar*, 5 min</b>
<b>6</b>	<b>Wash</b> silica membrane	<b>600 µL BW 900 µL B5 900 µL B5 – 0.2 bar*, 5 min each step</b>
<b>Remove MN Wash Plate</b>		
<b>7</b>	<b>Dry</b> silica membrane	<b>- 0.6 bar*, 10 min</b>
<b>8</b>	<b>Elute</b> DNA	<b>100 µL BE (70 °C) -0.4 bar*, 2 min</b>

*Optional: Repeat elution step once*

---



---

\* Reduction of atmospheric pressure

## Setup of vacuum manifold:

### Binding / Washing steps

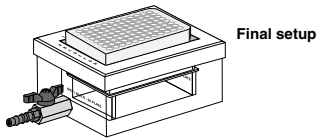
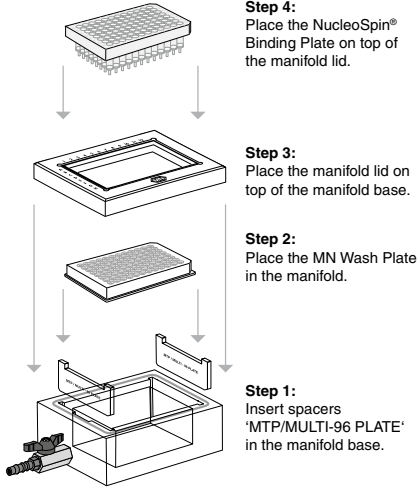

### Elution step

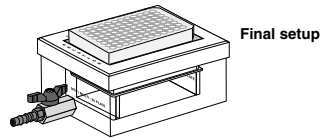
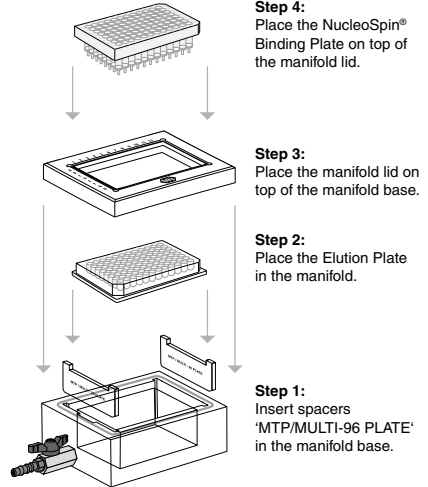

## Detailed protocol

- For hardware requirements, refer to section 2.3.
- For detailed information regarding the vacuum manifold setup, see page 20.
- For use of the NucleoSpin® 96 Tissue Core Kit (REF 740454.4), refer to section 2.4 regarding recommended accessories.

### Before starting the preparation:

- Check if Buffer B5 and Proteinase K were prepared according to section 3.
  - Set incubator or oven to 56 °C.
  - Preheat Elution Buffer BE to 70 °C.
- 

### 1 Prepare samples

For each preparation, cut up to two 0.5 cm pieces (20 mg) of mouse tail into appropriate lysis tubes or plates. If preparing DNA from rat tails, one 0.5 cm piece is sufficient. Tissue samples should not exceed 20 mg, cultured cells and bacteria should not exceed 10<sup>6</sup> cells.

---

### 2 Lyse samples

Prepare a Proteinase K working solution: For each sample, mix **25 µL Proteinase K** with **180 µL Buffer T1** and vortex. Transfer 200 µL of the resulting solution to each well of the Round-well Block containing the samples. Close the wells with Cap Strips and mix by vigorous shaking for 10–15 s. Spin briefly (15 s; 1,500 x g) to collect any sample at the bottom of the wells.

*The samples must be submerged in the solution. Never prepare the Proteinase K working solution more than 15 min before addition to the samples. Proteinase K tends to self digestion when incubated in Buffer T1 without substrate.*

Incubate the Round-well Block containing the samples at **56 °C** for **at least 6 h** (for mammalian cells reduce incubation to 10 min, bacterial cells may require prelysis with, e.g., lysozyme) or overnight until the samples are completely lysed. For optimal lysis, mix occasionally during incubation. Place a weight on top of the Round-well Block in order to prevent the Cap Strips from popping off occasionally.

Centrifuge the Round-well Block (15 s; 1,500 x g) to collect any condensate from the Cap Strips. Remove Cap Strips.

*Residual hair and / or bones in the lysate can be removed by centrifugation (2 min; 5,600–6,000 x g) and transfer of the supernatant to a new Round-well Block (not supplied with the kit).*

---

### 3 Adjust DNA binding conditions

Add 200 µL Buffer BQ1 and 200 µL 96–100 % ethanol to each sample. Again, take care not to moisten the rims of the individual wells while dispensing the buffer. Close the individual wells with new Cap Strips (supplied). Mix by vigorous shaking for 10–15 s. Spin briefly (10 s; 1,500 x g) to collect any sample from the Cap Strips.

*Ethanol and Buffer BQ1 can be premixed before addition to the samples, if the mixture is to be used up during the next 3 months. Never centrifuge at higher g-forces or for longer periods as DNA will precipitate.*

---

#### **Prepare the NucleoVac 96 Vacuum Manifold:**

Place waste tray into vacuum manifold base. Insert spacers labeled “MTP/Multi-96 plate” notched side up and place the MN Wash Plate on them. Close the manifold with the manifold lid and place a NucleoSpin® Tissue Binding Plate on top of the manifold.

---

### 4 Transfer lysates

Remove the first Cap Strip and transfer the lysates resulting from step 2 carefully from the Round-well Block into the wells of the NucleoSpin® Tissue Binding Plate. Continue with the next eight samples. Do not moisten the rims of the individual wells while dispensing the samples – moistened rims may cause cross-contamination.

*For transfer of the lysate from the Round-well Block to the NucleoSpin® Tissue Binding Plate, we recommend use of an electronic eight-channel pipetting device with extra long tips capable of holding more than 650 µL.*

---

### 5 Bind DNA to silica membrane

Apply vacuum until all lysates have passed through the wells of the NucleoSpin® Tissue Binding Plate (**-0.2 bar\***; **5 min**). Release the vacuum.

---

---

\* Reduction of atmospheric pressure

## 6 Wash silica membrane\*\*

### 1<sup>st</sup> wash

Add **600 µL\*\* Buffer BW** to each well of the NucleoSpin® Tissue Binding Plate. Apply vacuum (**-0.2 bar\***; **5 min**) until all buffer has passed through the wells of the NucleoSpin® Tissue Binding Plate. Release the vacuum.

### 2<sup>nd</sup> wash

Add **900 µL\*\* Buffer B5** to each well of the NucleoSpin® Tissue Binding Plate. Apply vacuum (**-0.2 bar\***; **5 min**) until all buffer has passed through the wells of the NucleoSpin® Tissue Binding Plate. Release the vacuum.

### 3<sup>rd</sup> wash

Add **900 µL\* Buffer B5** to each well of the NucleoSpin® Tissue Binding Plate. Apply vacuum (**-0.2 bar\***; **5 min**) until all buffer has passed through the wells of the NucleoSpin® Tissue Binding Plate. Release the vacuum.

---

## Remove MN Wash Plate

After the final washing step, close the valve, release the vacuum and remove the NucleoSpin® Tissue Binding Plate. Put it on a clean paper towel to remove residual EtOH-containing wash buffer. Remove manifold lid, MN Wash Plate, and waste container from the vacuum manifold.

---

## 7 Dry silica membrane

Insert the NucleoSpin® Tissue Binding Plate into the lid, and close the manifold. Apply maximum vacuum (**at least -0.6 bar\***) for **10 min** to dry the membrane completely. This step is necessary to eliminate traces of ethanol.

*Note: The ethanol in Buffer B5 inhibits enzymatic reactions and has to be removed completely before eluting DNA.*

Finally, release the vacuum.

---

## 8 Elute DNA

Insert spacers “Microtube rack” into the NucleoVac Vacuum Manifold’s short sides. Place a Rack of Tube Strips onto the spacer. Close the vacuum manifold and place the NucleoSpin® Tissue Binding Plate on top. Dispense **100 µL preheated Buffer BE** onto the membrane. Incubate for **3 min** at room temperature. Apply vacuum for elution (**-0.4 bar\***; **2 min**). Release the vacuum and repeat the elution step once. For alternative elution procedures see section 2.3.

Finally, close the Tube Strips with Cap Strips for storage.

Centrifuge Rack of Tube Strips shortly to collect all sample at the bottom of the Tube Strips.

---

\* Reduction of atmospheric pressure

\*\* Buffer volumes are increased compared to processing under centrifugation to improve washing efficiency under vacuum.

## 5.3 NucleoSpin® 96 Tissue – purification of DNA from up to $5 \times 10^6$ cultured cells

### Additional equipment needed:

- PBS (dissolve 8 g NaCl, 0.2 g KCl, 1.44 g Na<sub>2</sub>HPO<sub>4</sub>, and 0.24 g KH<sub>2</sub>PO<sub>4</sub> in 800 mL H<sub>2</sub>O. Adjust pH to 7.4 with HCl. Add H<sub>2</sub>O to 1 liter)
- Water bath or heating block
- Appropriate lysis vessel (e.g., Round-well Block, REF 740761)

### Additional preparations before starting:

- Heat a water bath or heating block to 70 °C.
- 

#### 1 Prepare samples

Resuspend **up to  $5 \times 10^6$  cultured cells** in a final volume of **200 µL PBS**.

---

#### 2 Lyse cells

Transfer **25 µL Proteinase K** solution and **180 µL Buffer T1** to each lysis vessel containing the resuspended cells. Mix by pipetting up and down (10 cycles).

Incubate the vessel containing the samples at **70 °C** for **1 h** until the cells are completely lysed. For optimal lysis, mix occasionally during incubation. Make sure that the lysis vessels are securely closed.

Centrifuge the vessel (15 s; 1,500 x g) to collect any condensate from the lid of the vessel.

---

#### 3 Adjust DNA binding conditions

Add **400 µL Buffer BQ1** and **400 µL 96–100 % ethanol** to each sample. Mix by vigorous shaking for 10–15 s. Spin briefly (10 s; 1,500 x g) to collect any sample from the Cap Strips.

*Using increased volumes of lysis buffers minimizes the risk of clogging of the silica membrane in the NucleoSpin® Tissue Binding Plates.*

---

Proceed with step 4 of the NucleoSpin® 96 Tissue standard protocol ('Transfer lysates').



## 6 Appendix

### 6.1 Troubleshooting

Problem	Possible cause and suggestions
No or poor DNA yield	<i>Incomplete lysis</i>
	<ul style="list-style-type: none"> <li>• Sample has not completely been submerged during heat incubation. Cut samples into small pieces. Mix well. Be sure that the samples are fully submerged in Buffer T1 / Proteinase K mixture. Incubate until the samples are completely lysed.</li> <li>• Buffer T1 and Proteinase K have been premixed more than 15 min before addition to the substrate. Proteinase K tends to self digestion under optimal reaction conditions in Buffer T1 without substrate.</li> </ul>
	<i>Reagents not applied properly</i>
RNA contamination	<ul style="list-style-type: none"> <li>• Prepare Buffer B5 and Proteinase K solution according to instructions (see section 3). Add Buffer BQ1 and ethanol to the lysates before loading them to the wells of the NucleoSpin® Tissue Binding Plate.</li> </ul>
	<i>Suboptimal elution of DNA from the column</i>
RNA contamination	<ul style="list-style-type: none"> <li>• Preheat Buffer BE to 70 °C before elution. Apply Buffer BE directly onto the center of the silica membrane.</li> <li>• Elution efficiencies decrease dramatically if elution is done with buffers with pH &lt; 7. Use slightly alkaline elution buffer like Buffer BE (pH 8.5).</li> </ul>
	<i>RNA in sample</i>
RNA contamination	<ul style="list-style-type: none"> <li>• If DNA free of RNA is desired, cool down to room temperature after lysis incubation and add 20 µL of an RNase A solution (20 mg/mL; see ordering information). Incubate for 15 min with moderate shaking.</li> </ul>

<b>Problem</b>	<b>Possible cause and suggestions</b>
Poor performance of genomic DNA in enzymatic reactions	<i>Carry-over of ethanol</i> <ul style="list-style-type: none"><li>• After washing with Buffer B5, centrifuge <math>\geq 4</math> min at 5,600–6,000 <math>\times g</math> in order to remove ethanolic Buffer B5 completely and evaporate residual ethanol by incubating the NucleoSpin® Tissue Binding Plate at 70 °C for 10 min.</li><li>• Increase vacuum drying time to 15 min.</li></ul>
	<i>Contamination of DNA with inhibitory substances</i> <ul style="list-style-type: none"><li>• Do not elute DNA with TE buffer. EDTA may inhibit enzymatic reactions. Repurify DNA and elute in Buffer BE.</li></ul>
Clogged wells	<i>Too much starting material</i> <ul style="list-style-type: none"><li>• Repeat the procedure, using two mouse tail sections of maximally 4–6 mm length. If processing rat tails, one 0.5 cm long tail tip section is sufficient.</li></ul>
	<i>Hair or bones left in the lysate after step 2</i> <ul style="list-style-type: none"><li>• Centrifuge the Round-well Block for 3 min at 5,600–6,000 <math>\times g</math>. Transfer lysates to a new Round-well Block without disturbing the debris pellet.</li></ul>
	<i>Incomplete passage of lysate in step 4</i> <ul style="list-style-type: none"><li>• If no more than 300–500 <math>\mu\text{L}</math> of lysate is remaining in the columns, continue with step 5. Through the addition of Buffer BW the sample is diluted and thus the sample will pass the column more easily.</li></ul>

## 6.2 Ordering information

Product	REF	Pack of
NucleoSpin® 96 Tissue	740741.2	2 × 96 preps
	740741.4	4 × 96 preps
	740741.24	24 × 96 preps
NucleoSpin® 96 Tissue Core Kit	740454.4	4 × 96 preps
NucleoSpin® 8 Tissue	740740	12 × 8
	740740.5	60 × 8 preps
NucleoSpin® 8 Tissue Core Kit	740453.4	48 × 8 preps
Buffer T1	740940.25	50 mL
Buffer BQ1	740923.1	1 L
Buffer B5 Concentrate (for 500 mL Buffer B5)	740921.100	100 mL
Buffer BW	740922.500	500 mL
Proteinase K	740506	100 mg
RNase A (lyophilized)	740505	100 mg
Rack of Tube Strips (1 set consists of 1 rack, 12 strips with 8 tubes each, and 12 Cap Strips)	740477	4 sets
	740477.24	24 sets
Round-well Block (1 set consists of 1 Round-well Block and 12 Cap Strips)	740475	4 sets
	740475.24	24 sets
MN Wash Plate	740479	4
	740479.24	24
Cap Strips	740478	48
	740478.24	288
NucleoVac 96 Vacuum Manifold	740681	1
NucleoVac Vacuum Regulator	740641	1
Self adhering PE Foil	740676	50

Visit [www.mn-net.com](http://www.mn-net.com) for more detailed product information.

## 6.3 Product use restriction/warranty

All MACHEREY-NAGEL products are designed for their intended use only. They are not intended to be used for any other purpose. The description of the intended use of the products can be found in the original MACHEREY-NAGEL product leaflets. Before using our products, please observe the instructions for use and the safety instructions from the respective Material Safety Data Sheet of the product.

This MACHEREY-NAGEL product is carrying documentation stating specifications and other technical information. MACHEREY-NAGEL warrants to meet the stated specifications. The provided warranty is limited to the data specifications and descriptions as given in the original MACHEREY-NAGEL literature. No other statements or representations, written or oral, by MACHEREY-NAGEL's employees, agents or representatives, except written statements signed by a duly authorized officer of MACHEREY-NAGEL are authorized. They should not be relied upon by the customer and are not a part of a contract of sale or of this warranty.

Liability for all possible damages that occur in any connection with our products is limited to the utmost minimum as stated in the general business terms and conditions of MACHEREY-NAGEL in their latest edition which can be taken from the company's website. MACHEREY-NAGEL does not assume any further warranty.

Products and their application are subject to change. Therefore, please contact our Technical Service Team for the latest information on MACHEREY-NAGEL products. You may also contact your local distributor for general scientific information. Descriptions in MACHEREY-NAGEL literature are provided for informational purposes only.

Last updated: 08/2022, Rev. 04

Please contact:  
MACHEREY-NAGEL GmbH & Co. KG  
Tel.: +49 24 21 969-333  
support@mn-net.com

---

### Trademarks:

FastPrep is a trademark of MP Biomedicals

NucleoSpin® is a trademark of MACHEREY-NAGEL GmbH & Co. KG

Precellys is a trademark of Bertin Technologies

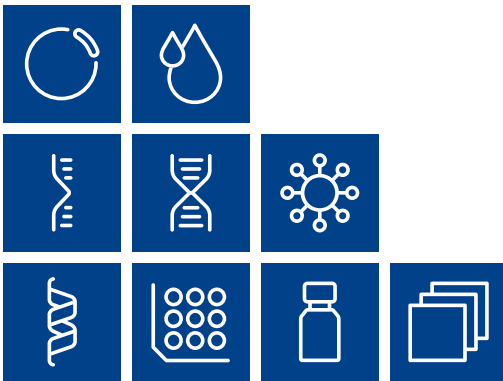

[www.mn-net.com](http://www.mn-net.com)

**MACHEREY-NAGEL**



 <p><b>TÜV Rheinland</b> CERTIFIED</p>	<p>Management System EN ISO 13485:2016 ISO 9001:2015</p>	
	<p><a href="http://www.tuv.com">www.tuv.com</a> ID 0000056401</p>	

MACHEREY-NAGEL GmbH & Co. KG · Valencienner Str. 11 · 52355 Düren · Germany

DE +49 24 21 969-0 [info@mn-net.com](mailto:info@mn-net.com)

CH +41 62 388 55 00 [sales-ch@mn-net.com](mailto:sales-ch@mn-net.com)

FR +33 388 68 22 68 [sales-fr@mn-net.com](mailto:sales-fr@mn-net.com)

US +1 888 321 62 24 [sales-us@mn-net.com](mailto:sales-us@mn-net.com)