

MACHEREY-NAGEL

User manual



■ NucleoSpin® 8 Food

September 2023 / Rev. 07

Contact MN

Germany and international

MACHEREY-NAGEL GmbH & Co. KG
Valenciener Str. 11 · 52355 Düren · Germany
Tel.: +49 24 21 969-0
Toll-free: 0800 26 16 000 (Germany only)
E-mail: info@mn-net.com

Technical Support Bioanalysis

Tel.: +49 24 21 969-333
E-mail: support@mn-net.com

USA

MACHEREY-NAGEL Inc.
924 Marcon Blvd. · Suite 102 · Allentown PA, 18109 · USA
Toll-free: 888 321 6224 (MACH)
E-mail: sales-us@mn-net.com

France

MACHEREY-NAGEL SAS
1, rue Gutenberg – BP135 · 67720 Hoerdt Cedex · France
Tel.: +33 388 68 22 68
E-mail: sales-fr@mn-net.com

MACHEREY-NAGEL SAS (Société par Actions Simplifiée) au capital de 186600 €
Siret 379 859 531 00020 · RCS Strasbourg B379859531 · N° intracommunautaire FR04 379 859 531

Switzerland

MACHEREY-NAGEL AG
Hirsackerstr. 7 · 4702 Oensingen · Switzerland
Tel.: +41 62 388 55 00
E-mail: sales-ch@mn-net.com

Table of contents

1	Components	4
1.1	Kit contents	4
1.2	Reagents to be supplied by user	4
1.3	About this user Manual	4
2	Product description	5
2.1	The basic principle	5
2.2	Kit specifications	6
2.3	Required hardware	7
2.4	Automated processing on robotic platforms	8
2.5	Sample storage and homogenization	8
2.6	Elution procedures	9
3	Storage conditions and preparation of working solutions	10
4	Safety instructions	11
4.1	Disposal	11
5	Protocols	12
5.1	Important information and advice	12
5.2	NucleoSpin® 8 Food – centrifuge processing	14
5.3	NucleoSpin® 8 Food – vacuum processing	18
6	Appendix	24
6.1	Troubleshooting	24
6.2	Ordering information	25
6.3	Product use restriction / warranty	26

1 Components

1.1 Kit contents

NucleoSpin® 8 Food		
REF	12 × 8 preps 740975	60 × 8 preps 740975.5
Lysis Buffer CF	100 mL	500 mL
Buffer C4	75 mL	250 mL
Wash Buffer CQW	125 mL	3 × 125 mL
Wash Buffer C5 (Concentrate) ¹	50 mL	2 × 100 mL
Elution Buffer CE ²	30 mL	125 mL
Proteinase K (lyophilized) ¹	30 mg	2 × 75 mg
Proteinase Buffer PB	1.8 mL	15 mL
NucleoSpin® Food Binding Strips (blue rings)	12	60
Round-well Blocks ³	1	5
MN Wash Plate ⁴	2	10
Rack of Tube Strips ⁵	2	10
Gas-permeable Foil	6	18
User manual	1	1

1.2 Reagents to be supplied by user

- 96–100 % ethanol (for preparation of working solutions, see section 3)

For more detailed information regarding special hardware required for centrifuge or vacuum processing, see section 2.3.

1.3 About this user Manual

It is recommended to read the instructions of this user manual carefully before use. All technical literature is also available on the internet at www.mn-net.com.

Please contact Technical Service regarding information about changes of the current user manual compared to previous or updated revisions.

¹ For preparation of working solutions and storage conditions, see section 3.

² Elution Buffer CE: 5 mM Tris/HCl, pH 8.5

³ Including 12 Cap Strips for each block

⁴ For use with vacuum only

⁵ Sets of 1 rack, 12 strips with 8 tubes each, including Cap Strips

2 Product description

2.1 The basic principle

NucleoSpin® 8 Food is designed for the isolation of genomic DNA from food samples, preferably of plant or animal origin. The NucleoSpin® 8 Food kits combine the NucleoSpin® technology from MACHEREY-NAGEL GmbH and GMO experience from GEN-IAL GmbH to provide an optimal lysis and purification system for nearly all types of food samples. Resulting eluates are ready to use in all types of subsequent detection methods, especially in real-time and basic PCR technologies.

GEN-IAL is a company, which offers contract research and molecular testing services in food and feed stuff. Special areas of interest are the development and standardization of detection methods for GMOs, as well as animal and microbial species identification and differentiation.

NucleoSpin® silica membrane technology from **MACHEREY-NAGEL** allows fast and effective purification of nucleic acids from various matrices. The silica membranes are optimized for high DNA recoveries and low unspecific binding of impurities.

Nucleic acid extraction: After the food samples have been homogenized, the DNA can be extracted with lysis buffers containing chaotropic salts, denaturing agents, and detergents. The standard isolation ensures lysis using Lysis Buffer CF, a proprietary buffer developed by GEN-IAL for food matrices (patented). Lysis mixtures have to be cleared by centrifugation or filtration in order to remove contaminants and residual cellular debris. Afterwards, the clear supernatant is mixed with binding buffer and ethanol to adjust binding conditions for optimal binding of DNA to the NucleoSpin® silica membrane, which was selected for this purpose due to its unique DNA-binding properties. After washing with two different buffers for efficient removal of potential PCR inhibitors, DNA can be eluted in low salt buffer or water, and is ready to use in subsequent reactions.

Food samples are very heterogeneous and contain many different compounds such as fat, cocoa, or polysaccharides, which can lead to suboptimal extraction or subsequent processing of DNA. NucleoSpin® 8 Food guarantees good recovery rates for small genomic DNA fragments (< 1 kb) from processed, complex food matrices (e.g., ketchup or spices), which generally have very low DNA contents as well as poor quality, degraded DNA. We thus recommend the selection of primers which amplify only short DNA fragments (80–150 bp).

2.2 Kit specifications

- **NucleoSpin® 8 Food** is designed for the isolation of genomic DNA from food samples preferably of plant or animal origin. However, bacteria can also be processed (see section 5.1 for details).
- **NucleoSpin® 8 Food** kits can be used for the identification of GMO-DNA or animal components in food and feed.
- **NucleoSpin® 8 Food** allows processing of up to 200 mg material. Depending on the individual sample, typical yields for NucleoSpin® 8 Food are in the range of 0.1 – 10 µg DNA.
- The eluted DNA is ready for use in subsequent reactions such as real-time PCR, GMO detection, etc.
- **NucleoSpin® 8 Food** allows parallel purification of multiples of 8 samples.
- **NucleoSpin® 8 Food** can be processed by centrifugation or under vacuum. Processing under vacuum allows easy automation on common liquid handling instruments. For more information about the automation process and the availability of ready-to-run scripts for certain platforms, please refer to section 2.4 and contact your local distributor or MN directly.
- Any unused wells of the **NucleoSpin® 8 Food Binding Strips** should be covered with Self adhering PE Foil (see ordering information, section 6.2) in order to guarantee a proper vacuum and to protect the unused wells from being contaminated.

Table 1: Kit specifications at a glance

Parameter	NucleoSpin® 8 Food
Technology	Silica membrane technology
Format	8-well strips
Processing	Manual and automated, vacuum or centrifugation
Sample material	< 200 mg food or feed
Typical yield	0.1 – 10 µg
A_{260}/A_{280}	1.6 – 1.9
Elution volume	100 – 200 µL
Preparation time	60 min/6 strips (excl. lysis)
Binding capacity	30 µg
Use	For research use only

2.3 Required hardware

NucleoSpin® 8 Food can be processed under vacuum or with centrifugation. Certain hardware for processing is required.

Centrifugation

For processing the 8-well strips under centrifugation, the Starter Set C (see ordering information, section 6.2), containing Column Holders C, NucleoSpin® Dummy Strips, MN Square-well Blocks, and Rack of Tube Strips is required.

For centrifugation with Column Holder C (with inserted NucleoSpin® Food Binding Strips) stacked on a MN Square-well Block or Rack of Tube Strips, a microtiter plate centrifuge is required. This centrifuge must be able to accommodate the above mentioned sandwich and reach accelerations of 5,600–6,000 x *g* (bucket height: 85 mm).

Regarding waste collection, suitable consumables (e.g., MN Square-well Blocks) are necessary and they are not included in the kit. For the most convenient handling, without the need of emptying and reusing the MN Square-well Blocks, we recommend using six MN Square-well Blocks if two 96-well plates are processed at once (see ordering information). Alternatively, it is possible to empty the MN Square-well Blocks after every centrifugation step, reducing the amount of MN Square-well Blocks needed.

Vacuum processing

For processing 8-well strips under vacuum, the Starter Set A (see ordering information), containing Column Holders A and NucleoSpin® Dummy Strips is required.

For **automation** on laboratory platforms with standard 96-well plate manifolds, the use of Starter Set A is also required.

The **NucleoSpin® 8 Food** kit can be used **manually** with the NucleoVac 96 Vacuum Manifold (see ordering information).

Establish a reliable vacuum source for the NucleoVac 96 Vacuum Manifold. The manifold may be used with a vacuum pump, house vacuum, or water aspirator. We recommend a vacuum of -0.2 to -0.4 bar (reduction of atmospheric pressure). The use of the NucleoVac Vacuum Regulator (see ordering information) is recommended. Alternatively, adjust the vacuum so that during the purification the sample flows through the column with a rate of 1–2 drops per second. Depending on the amount of sample being used, the vacuum times may need to be increased for complete filtration.

Additionally, a suitable centrifuge for sample preparation steps may be required.

2.4 Automated processing on robotic platforms

NucleoSpin® 8 Food can be used fully automated on many common laboratory workstations. For the availability of scripts and general considerations about adapting **NucleoSpin® 8 Food** on a certain workstation, please contact MN. Full processing under vacuum enables complete automation without the need for centrifugation steps for drying of the binding membrane or for elution. However, a final elution step by centrifugation is recommended in order to achieve higher concentrated eluted DNA.

The risk of cross-contamination is reduced by optimized vacuum settings during the elution step and by the improved shape of the outlets of the NucleoSpin® Food Binding Strips.

Drying of the NucleoSpin® Food Binding Strips under vacuum is sufficient because the bottom of the plate is protected by the MN Wash Plate during the washing steps. As a result, it is recommended to integrate the MN Wash Plate into the automated procedure to protect against these wash buffer residues. The MN Frame (see ordering information) can be used to position the disposable MN Wash Plate inside the vacuum chamber. This also reduces the risk of cross-contamination, as common metal adaptors tend to get contaminated by gDNA. Thorough cleaning of the vacuum chamber is recommended after each run to prevent DNA-containing aerosols from forming.

Visit MN online at www.mn-net.com or contact your local MACHEREY-NAGEL distributor for technical support regarding hardware, software, setup instructions, and selection of the protocol. Several application notes of the **NucleoSpin® 8 Food** kit on various liquid handling instruments can also be found at www.mn-net.com at Bioanalysis / Literature.

2.5 Sample storage and homogenization

The lysis procedure is most effective when well homogenized, powdered samples are used. To achieve this, we recommend grinding with a pestle and mortar in the presence of liquid nitrogen or using steel beads. Commercial homogenizers can also be used. After homogenization and treatment of the sample with lysis buffer, mixtures can be cleared easily and effectively by either centrifugation or with a NucleoSpin® Filter (REF 740606).

Methods to homogenize sample

- Commercial homogenizers, for example Crush Express for 96-well homogenization (Saaten-Union Resistenzlabor GmbH), Tissue Striker (KisanBiotech) or Geno/Grinder 2000 are suitable.
- Homogenizing samples by VA steel beads (diameter: 7 mm): Put 4–5 beads and food material together into a 15 mL plastic tube (Falcon), chill the tube in liquid nitrogen and vortex for about 30 seconds (e.g., with a Multi Pulse Vortexer). Repeat this chilling and vortexing procedure until the entire material is ground to a powder. Chill the tube once more and remove the beads by rolling them out gently or with a magnet. Keep the material frozen throughout the whole homogenization procedure. Do not add nitrogen to the tube! This leads to sticking and loss of sample material attached to the beads.

2.6 Elution procedures

It is possible to adjust the elution method and the volume of the elution buffer to the subsequent application of interest. In addition to the standard method described in the protocols (recovery rate about 70–90 %), there are several modifications possible. Use elution buffer preheated at 70 °C for one of the following procedures:

- **High yield:** By performing two elution steps with $2 \times 100 \mu\text{L}$, 90–100 % of bound nucleic acids can be eluted. Finally, combine eluates and measure yield.
- **High concentration:** Perform one elution step with only 60 % of the volume indicated in the individual protocol. Concentration of DNA will be about 30 % higher than with the standard elution procedure. Maximum yield of bound nucleic acids is about 80 %.
- **High yield and high concentration:** Apply half the volume of elution buffer as indicated in the individual protocol, incubate for 3 min and centrifuge. Apply a second aliquot of elution buffer, incubate and centrifuge again. Thus, about 85–100 % of bound nucleic acids are eluted in the standard elution volume at a high concentration.
- **Convenient elution:** For convenience, elution buffer of ambient temperature may be used. This will result in a slightly lower yield (approximately 20 %) compared to elution with heated elution buffer.

Elution may also be performed with Tris-EDTA-buffer (TE) of pH equal or higher than 8. This will increase DNA stability during long term or multi-use storage at 4 °C (or ambient temperature) by inhibiting omnipresent DNases. However, EDTA interferes, depending on the final concentration, with certain downstream applications.

For optimal performance of isolated DNA in downstream applications, we recommend eluting with the supplied elution buffer and storing it, especially long term, at -20 °C. Several freeze-thaw cycles will not interfere with most downstream applications.

Performance of long-range PCR (e.g., > 10 kb) or the detection limit of trace amount of DNA species, may be reduced after multiple freeze-thaw cycles or prolonged storage of eluted DNA at 4 °C or room temperature. This is due to shearing of DNA or adsorption to surfaces.

Due to the dead volume of the silica membrane, please note that the difference between the dispensed elution buffer volume and the recovered elution buffer volume containing genomic DNA is approximately 20 μL (recovered elution volume = dispensed elution volume -20 μL).

3 Storage conditions and preparation of working solutions

Attention:

Buffers C4 and CQW contain guanidine hydrochloride and detergents! Wear gloves and goggles!

CAUTION: Buffers C4 and CQW contain guanidine hydrochloride which can form highly reactive compounds when combined with bleach (sodium hypochlorite). DO NOT add bleach or acidic solutions directly to the sample-preparation waste.

- All kit components can be stored at room temperature (18–25 °C) and are stable up to one year.
- If there is any precipitate present in the buffers, warm the buffer to 25–37 °C to dissolve the precipitate before use.

Before starting any **NucleoSpin® 8 Food** protocol prepare the following:

- **Wash Buffer C5:** Add the indicated volume of ethanol (96–100 %) to **Buffer C5 Concentrate**. Mark the label of the bottle to indicate that ethanol was added. Store Wash Buffer C5 at room temperature (18–25 °C) for at least one year.
- Before first use of the kit, add the indicated volume of Proteinase Buffer PB to dissolve lyophilized **Proteinase K**. Proteinase K solution is stable for 6 months at -20 °C.

NucleoSpin® 8 Food		
REF	12 x 8 preps 740975	60 x 8 preps 740975.5
Wash Buffer C5 (Concentrate)	50 mL Add 200 mL ethanol	100 mL Add 400 mL ethanol
Proteinase K	30 mg Add 1.35 mL Proteinase Buffer PB	2 x 75 mg Add 3.35 mL Proteinase Buffer PB to each vial

4 Safety instructions

When working with the NucleoSpin® 8 Food kit wear suitable protective clothing (e.g., lab coat, disposable gloves, and protective goggles). For more information consult the appropriate Material Safety Data Sheets (MSDS available online at <http://www.mn-net.com/msds>).



Caution: Guanidine hydrochloride in buffer C4 and CQW can form highly reactive compounds when combined with bleach! Thus, do not add bleach or acidic solutions directly to the sample preparation waste.

The waste generated with the NucleoSpin® 8 Food kit has not been tested for residual infectious material. A contamination of the liquid waste with residual infectious material is highly unlikely due to strong denaturing lysis buffer and Proteinase K treatment but it cannot be excluded completely. Therefore, liquid waste must be considered infectious and should be handled and discarded according local safety regulations.

4.1 Disposal

Dispose hazardous, infectious or biologically contaminated materials in a safe and acceptable manner and in accordance with all local and regulatory requirements.

5 Protocols

5.1 Important information and advice

- Due to the low DNA content in processed food, this protocol should be started with up to 0.2 g of material.
- Lysis buffer was tested (see list on the next page) for extraction of DNA from various types of samples including food of plant and animal origin, and bacteria. To detect bacterial DNA in food samples, we recommend an overnight preculture of sample and appropriate culture medium. Centrifuge an aliquot of the culture and start the preparation with the bacterial pellet.
- RNase A (not included in the kit, see ordering information) addition may be recommended for RNA-rich samples. Add 10 μL (20 mg/mL stock solution) per 550 μL lysis buffer in step 2 of the protocol or perform a RNase A digestion in the eluate before further use.
- Ketchup, sauce, and similar fluid samples (0.2 g equivalents) can be mixed with lysis buffer (500 – 1000 μL each) and incubated with Proteinase K as described in the protocol (see ordering information for additional Lysis Buffer CF).
- For powdered hygroscopic samples, more lysis buffer than indicated in the protocol can be used until the lysis solution is at least semi fluid and can be pipetted (see ordering information for Lysis Buffer CF). Extraction can be improved by preincubation of sample with lysis buffer for 1 – 2 h.
- According to local law regulations, different amounts of sample have to be analyzed for GMO detection, for example, up to 1 – 2 g of sample can be used with up scaled lysis buffer volumes. We recommend using a single 300 μL aliquot (step 3) of the clear supernatant for further processing with the NucleoSpin[®] 8 Food Binding Strips. Otherwise, prepare 2 aliquots as described in the protocol and load them step by step onto the NucleoSpin[®] 8 Food Binding Strips.
- For processing large samples of, for example, 1 g lysis buffer and Proteinase K have to be upscaled: per 0.1 g of sample add 275 μL Buffer CF and 5 μL Proteinase K. After incubation and clearance of the lysate, proceed with step 3 in the protocol and further use of 300 μL of the lysate. In order to increase the sensitivity a repeated loading (repeated performance of step 3 – 5) is possible.

Table 2: Positively tested samples (PCR)*

Food (plant origin)	Raw products: maize, soja, rape etc. (powder or oil) Chocolate products, cocoa, nougat products Breakfast cereals, muesli, nut / chocolate spread Jam and fruit concentrates Cookies, cakes and biscuits Pollen Lecithine Spices Bread
Food (animal origin)	Raw and processed products (meat, sausage, pie)
Cosmetics	Plant and animal ingredients (e.g., in crème or powder)
Bacteria	Starter cultures, etc.

5.2 NucleoSpin® 8 Food – centrifuge processing

- For hardware requirements, refer to section 2.3.
- For detailed information on each step, see page 15.

Before starting the preparation:

- Check if Buffer C5 and Proteinase K were prepared according to section 3.
- Preheat Buffer CF to 65 °C and Buffer CE to 70 °C.

Protocol at a glance

1 Homogenize samples	0.2 g sample 500 µL preheated (65 °C) CF 10 µL Proteinase K Mix 65 °C, 30 min
2 Clear lysate	5,600 x g, 20 min
3 Adjust DNA binding conditions	300 µL clear lysate 300 µL C4 300 µL ethanol (96 – 100 %) Mix
4 Transfer lysates to NucleoSpin® Food Binding Strips	
5 Bind DNA to silica membrane of the NucleoSpin® Food Binding Strips	5,600 x g, 10 min
6 Wash silica membrane	500 µL CQW 5,600 x g, 2 min 900 µL C5 5,600 x g, 5 min

7	Dry silica membrane	5,600 x g, 15 min or 37 °C, 20 min
8	Elute DNA	100 µL CE (70 °C) 5,600 x g, 2 min

Optional: Repeat elution step once.

Detailed protocol

- For hardware requirements, refer to section 2.3.
For processing of NucleoSpin® 8 Food with a centrifuge, the NucleoVac 96 Vacuum Manifold and the Starter Kit C are required (see ordering information). The use of NucleoSpin® Food Binding Strips in a Column Holder C allows the isolation of up to $n \times 8$ samples ($n = 1$ to 6). Insert as many of the NucleoSpin® Food Binding Strips as required into the same positions of each one of the two reusable column holders and place column holders onto the MN Square-well Blocks. Label the column holders or 8-well strips for later identification. Always use 2 Column Holders C containing identical numbers of NucleoSpin® Food Binding Strips for centrifugation. This avoids the need to balance the centrifuge, and allows multiples of 16 samples to be processed in parallel. We recommend inserting the NucleoSpin® Food Binding Strips around the center of the column holder

Before starting the preparation:

- Check if Buffer C5 and Proteinase K were prepared according to section 3.
- Preheat Buffer CF to 65 °C and Buffer CE to 70 °C.

For each preparation, collect up to 200 mg of sample into an appropriate lysis vessel (e.g., Rack of Tube Strips).

1 Homogenize and lyse samples

Homogenize up to **200 mg sample** using a commercial homogenizer. Transfer homogenized samples into Rack of Tube Strips and add **550 µL Buffer CF** preheated to 65 °C. Add **10 µL of Proteinase K solution**. Close the Tube Strips using Cap Strips and mix by vigorous shaking for 15–30 s. Spin briefly for 30 s at 1,500 x g to collect any sample at the bottom of the Tube Strips. Incubate at **65 °C** for **30 min**.

2 Clear lysate

Centrifuge the samples for **20 min** at full speed (**5,600–6,000 x g**). Remove Cap Strips.

3 Adjust DNA binding conditions

Transfer **300 µL clear supernatant** to a Round-well Block. Add **300 µL Buffer C4** and **300 µL ethanol (96–100 %)**. Close the individual wells with Cap Strips. Mix by vigorous vortexing for 15–30 s (or by pipetting up and down). Spin briefly for 30 s at 1,500 x g to collect any sample from Cap Strips.

Ethanol and Buffer C4 can be premixed before addition to the samples, if the mixture is to be used during the next 3 months. Never centrifuge at higher g-forces or for longer periods as DNA will precipitate.

4 Transfer lysates

Insert the desired number of NucleoSpin® Food Binding Strips in the Column Holder C and place it on a MN Square-well Block (supplied with Starter Set C) for collection of flow through.

Transfer samples from the Round-well Block into the wells of the NucleoSpin® Food Binding Strips. Do not moisten the rims of the individual wells while dispensing samples. After transfer, seal the openings of the NucleoSpin® Food Binding Strips with Gas-permeable Foil.

The Gas-permeable Foil can be cut into appropriate pieces due to the number of NucleoSpin® Food Binding Strips which are to be covered. When not using air-permeable foil, pierce foil to achieve air permeability

5 Bind DNA to silica membrane

Place the MN Square-well Block with Holder C onto the centrifuge carriers and insert them into the rotor buckets. Centrifuge at **5,600–6,000 x g** for **5 min**.

Typically, the lysates will have passed through the silica membrane within a few minutes. The centrifugation process can be extended to 20 min, if the lysates have not passed completely.

The volume of each well of the NucleoSpin® Food Binding Strips is ~ 1 mL. Higher volumes, resulting from steps 1–3, have to be loaded successively until the complete lysis mixture has been applied.

6 Wash silica membrane

1st wash

Remove the Gas-permeable Foil and add **500 µL Buffer CQW** to each well of the NucleoSpin® Food Binding Strips. Seal the strips with a new Gas-permeable Foil and centrifuge again at **5,600–6,000 x g** for **2 min**. Discard waste collected in the MN Square-well Block after this wash step.

2nd wash

Remove the Gas-permeable Foil and add **900 µL Buffer C5** to each well of the NucleoSpin® Food Binding Strips. Centrifuge for **5–15 min** at full speed (**5,600–6,000 x g**) in order to remove Buffer C5.

For critical ethanol-sensitive applications, it is recommended to prolong the centrifugation time up to 15 min or incubate at higher temperature. Remove the adhesive foil and place the column holder with the NucleoSpin® Food Binding Strips into an incubator for 20 min at 37 °C to evaporate residual ethanol. Removal of ethanol by evaporation at 37 °C is more effective than additional, prolonged centrifugation (15 min, 6,000 x g).

7 Dry silica membrane

For critical ethanol-sensitive applications it is recommended to prolong the centrifugation time up to **15 min** or incubate at higher temperature. Remove the adhesive foil and place the NucleoSpin® Food Binding Strips into an incubator for **20 min** at **37 °C** to evaporate residual ethanol.

Removal of ethanol by evaporation at 37 °C is more effective than prolonged centrifugation (15 min, 6,000 x g).

Note: The ethanol in Buffer B5 may inhibit enzymatic reactions and should be removed completely before eluting DNA.

8 Elute DNA

Place the column holder with NucleoSpin® Food Binding Strips on an opened Rack of Tube Strips. Dispense **100 µL preheated buffer CE (70 °C)** to each well of the NucleoSpin® Food Binding Strips. Dispense the buffer directly onto the membrane. Incubate at **room temperature** for **2–3 min**. Centrifuge at **5,600–6,000 x g** for **2 min**. Remove the Column Holder C from the Tube Strips.

Yields will be 10–20 % higher when eluting in 200 µL Buffer CE depending on the total amount of DNA. The concentration of DNA, however, will be much lower than with 100 µL. Elution can also be done in TE buffer (at least pH 8.0) as well. Elution efficiency will decrease when using elution buffers with pH ≤ 8.0.

Clean the MN Square-well Blocks with detergent and hot water and incubate for 1–5 min in 0.4 M HCl. Rinse with water again and autoclave before next use.

5.3 NucleoSpin® 8 Food – vacuum processing

- For hardware requirements, refer to section 2.3.
- For detailed information regarding the vacuum manifold setup, see page 20.
- For detailed information on each step, see page 21.

Before starting the preparation:

- Check if Buffer C5 and Proteinase K were prepared according to section 3.
- Preheat Buffer CF to 65 °C and Buffer CE to 70 °C.

Protocol at a glance

1	Homogenize samples	0.2 g sample 500 µL preheated (65 °C) CF 10 µL Proteinase K Mix 65 °C, 30 min
2	Clear lysate	5,600 x g, 20 min
3	Adjust DNA binding conditions	300 µL clear lysate 300 µL C4 300 µL ethanol (96 – 100 %) Mix Prepare the NucleoVac 96 Vacuum Manifold
4	Transfer lysates to NucleoSpin® Food Binding Strips	
5	Bind DNA to silica membrane of the NucleoSpin® Food Binding Strips	-0.2 bar* , 5 min

*Reduction of atmospheric pressure

6	Wash silica membrane	500 µL CQW
		-0.2 bar*, 5 min
		900 µL C5
		-0.2 bar*, 5 min
		900 µL C5
		-0.2 bar*, 5 min
7	Dry silica membrane	-0.6 bar* , 10 min
		or
		37 °C, 20 min
8	Elute DNA	100 µL GE (70 °C)
		-0.6 bar*, 2 min

Optional: Repeat elution step once.

*Reduction of atmospheric pressure

Setup of vacuum manifold:

Binding / Washing steps

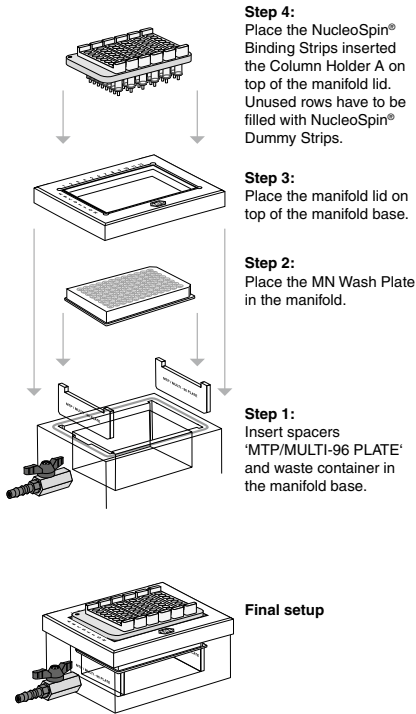

Elution step

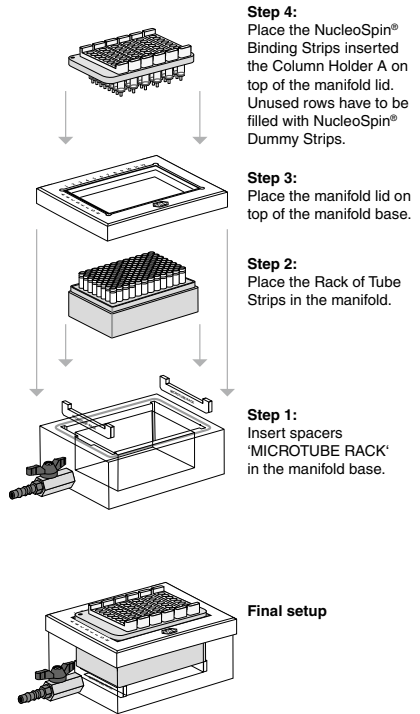

Detailed protocol

- For hardware requirements, refer to section 2.3.
For processing of NucleoSpin® 8 Food under vacuum, the NucleoVac 96 Vacuum Manifold and the Starter Kit A are required (see ordering information). Starter Kit A contains the Column Holders A and NucleoSpin® Dummy Strips to seal unused rows. The use of NucleoSpin® Food Binding Strips in a Column Holder A allows the isolation of up to $n \times 8$ samples ($n = 1$ to 6). Insert as many NucleoSpin® Food Binding Strips as required into the reusable column holder. Seal unused wells of NucleoSpin® Food Binding Strips with Self adhering PE-Foil and close unused wells with NucleoSpin® Dummy Strips. Place the Column Holder A on the NucleoVac 96 manifold.

Before starting the preparation:

- Check if Buffer C5 and Proteinase K were prepared according to section 3.
- Preheat Buffer CF to 65 °C and Buffer CE to 70 °C.

1 Homogenize and lyse samples

Homogenize up to 200 mg sample using a commercial homogenizer. Transfer homogenized samples into Rack of Tube Strips and add 550 μ L Buffer CF preheated to 65 °C. Add 10 μ L of Proteinase K solution. Close the Tube Strips using Cap Strips and mix by vigorous shaking for 15–30 s. Spin briefly for 30 s at 1,500 $\times g$ to collect any sample at the bottom of the Tube Strips. Incubate at 65 °C for 30 min.

2 Clear lysate

Centrifuge the samples for 20 min at full speed (5,600–6,000 $\times g$). Remove Cap Strips.

3 Adjust DNA binding conditions

Transfer **300 μ L clear supernatant** to a Round-well Block. Add **300 μ L Buffer C4** and **300 μ L ethanol (96–100 %)**. Close the individual wells with Cap Strips. Mix by vigorous vortexing for 15–30 s (or by pipetting up and down). Spin briefly for 30 s at 1,500 $\times g$ to collect any sample from Cap Strips.

Ethanol and Buffer C4 can be premixed before addition to the samples, if the mixture is to be used during the next 3 months. Never centrifuge at higher g-forces or for longer periods as DNA will precipitate.

Prepare the NucleoVac 96 Vacuum Manifold:

Place waste tray into vacuum manifold base. Insert spacers labeled 'MTP/MULTI-96 PLATE' notched side up and place the MN Wash Plate on them. Close the manifold with the manifold lid.

Insert desired number of NucleoSpin® Food Binding Strips in the Column Holder A. Use NucleoSpin® Dummy Strips to seal unused positions in the column holder.

Place Column Holder A with inserted NucleoSpin® Food Binding Strips on top of the manifold.

4 Transfer lysates

Transfer samples from the Round-well Block into the wells of the NucleoSpin® Food Binding Strips. Do not moisten the rims of the individual wells while dispensing samples.

5 Bind DNA to silica membrane

Apply vacuum until all lysates have passed through the wells of the NucleoSpin® Food Binding Strips (**-0.2 to -0.4 bar***). Flowthrough rate should be about 1–2 drops per second. Adjust vacuum strength accordingly.

6 Wash silica membrane

1st wash

Add **500 µL Buffer CQW** to each well of the NucleoSpin® Food Binding Strips. Apply vacuum (**-0.2 bar*, 5 min**) until all buffer has passed the wells of the NucleoSpin® Food Binding Strips. Release the vacuum.

2nd wash

Add **900 µL Buffer C5** to each well of the NucleoSpin® Food Binding Strips. Apply vacuum (**-0.2 bar*, 5 min**) until all buffer has passed the wells of the NucleoSpin® Food Binding Strips. Release the vacuum.

3rd wash

Add **900 µL Buffer C5** to each well of the NucleoSpin® Food Binding Strips. Apply vacuum (**-0.2 bar*, 5 min**) until all buffer has passed the wells of the NucleoSpin® Food Binding Strips. Release the vacuum.

Remove MN Wash Plate

After the final washing step, close the valve, release the vacuum and remove the NucleoSpin® Food Binding Strips from the vacuum manifold. Put it on a clean paper towel to remove residual EtOH-containing wash buffer. Remove manifold lid, MN Wash Plate, and waste container from the vacuum manifold.

7 Dry silica membrane

Insert Column Holder A with the NucleoSpin® Food Binding Strips again into the lid, and close the manifold. Apply maximum vacuum (**at least -0.6 bar***) for **15 min** to dry the membrane completely. This step is necessary to eliminate traces of ethanol.

Note: The ethanol in Buffer C5 inhibits enzymatic reactions and has to be removed completely before eluting DNA.

Finally, release the vacuum.

*Reduction of atmospheric pressure

8 Elute DNA

Insert spacers 'MICROTUBE RACK' into the NucleoVac Vacuum Manifold base. Place the Rack of Tube Strips onto the spacer. Close manifold and place the NucleoSpin® Food Binding Strips on top. Dispense **100 µL Buffer CE** (preheated to 70 °C) to each well of the NucleoSpin® Food Binding Strips. Pipette buffer directly onto the membrane. Incubate at **room temperature** for **3 min**. Apply vacuum for elution (**-0.4 bar***) until all the samples have passed.

For optimal yield, it is recommended to repeat this step once (incubation not necessary).

Finally, close the Tube Strips with Cap Strips for storage.

Yields will be 10–20 % higher when eluting in 200 µL Buffer CE depending on the total amount of DNA. The concentration of DNA, however, will be much lower than with 100 µL. Elution can also be done in TE buffer (at least pH 8.0) as well. Elution efficiency will decrease when using elution buffers with pH ≤ 8.0.

6 Appendix

6.1 Troubleshooting

Problem	Possible cause and suggestions
Low DNA yield	<p data-bbox="333 304 799 331"><i>Homogenization of food material was not sufficient</i></p> <ul data-bbox="333 347 922 422" style="list-style-type: none"> <li data-bbox="333 347 922 422">• For most species, we recommend grinding with steel beads (see section 2.5) or with commercial bead mills, mixers or homogenizers. <p data-bbox="333 438 945 466"><i>Extraction of DNA from food material during lysis was not sufficient</i></p> <ul data-bbox="333 481 960 531" style="list-style-type: none"> <li data-bbox="333 481 960 531">• To obtain higher yields of DNA, the incubation time in lysis buffer can be prolonged (up to overnight). <p data-bbox="333 547 628 574"><i>Sample contains too much RNA</i></p> <ul data-bbox="333 590 978 667" style="list-style-type: none"> <li data-bbox="333 590 978 667">• Add 10–20 µL RNase A solution to the lysis buffer before heat incubation. If this is not successful, add the enzyme to the cleared lysate and incubate for 30 min at 37 °C.
	<p data-bbox="333 683 505 710"><i>Suboptimal elution</i></p> <ul data-bbox="333 726 969 895" style="list-style-type: none"> <li data-bbox="333 726 969 801">• The DNA can be either eluted in higher volumes (up to 300 µL) or by repeating the elution step up to three times. Remember that the elution buffer must be preheated to 70 °C prior to elution. <li data-bbox="333 817 956 895">• Also check the pH of the used elution buffer, which should be in the range of pH 8.0–8.5. To ensure correct pH, use supplied Elution Buffer CE.
Degraded DNA	<p data-bbox="333 911 692 938"><i>Sample was contaminated with DNase</i></p> <ul data-bbox="333 954 680 981" style="list-style-type: none"> <li data-bbox="333 954 680 981">• Check working area and pipettes. <p data-bbox="333 997 591 1024"><i>Sample dependent problem</i></p> <ul data-bbox="333 1040 969 1086" style="list-style-type: none"> <li data-bbox="333 1040 969 1086">• Highly processed samples may be responsible for impossibility to extract high molecular weight DNA.
Low DNA quality	<p data-bbox="333 1102 978 1161"><i>Sample contains DNA-degrading contaminants (e.g., phenolic compounds, metabolites)</i></p> <ul data-bbox="333 1177 732 1201" style="list-style-type: none"> <li data-bbox="333 1177 732 1201">• Repeat washing step with Buffer CQW.

6.2 Ordering information

Product	Product	Pack of
NucleoSpin® 8 Food	740975	12 × 8 preps
	740975.5	60 × 8 preps
NucleoSpin® 96 Food	740976.2	2 × 96 preps
	740976.4	4 × 96 preps
	740976.24	24 × 96 preps
Buffer CF	740946	1 L
Buffer C5 Concentrate (for 125 mL Buffer C5)	740931	25 mL
Buffer CQW	740313.125	125 mL
RNase A	740505.50	50 mg
	740505	100 mg
Proteinase K	740506	100 mg
RNase A (lyophilized)	740505	100 mg
Rack of Tube Strips (1 set consists of 1 rack, 12 strips with 8 tubes each, and 12 Cap Strips)	740477	4 sets
	740477.24	24 sets
Square-well Block	740481	4
	740481.24	24
MN Square-well Block	740476	4
	740476.24	24
Round-well Block (1 set consists of 1 Round-well Block and 12 Cap Strips)	740475	4 sets
	740475.24	24 sets
MN Wash Plate	740479	4
	740479.24	24
Cap Strips	740478	48
	740478.24	288
NucleoVac 96 Vacuum Manifold	740681	1
NucleoVac Vacuum Regulator	740681	1
Starter Set A (for processing NucleoSpin® 8-well strips on NucleoVac 96 Vacuum Manifold)	740682	1

Product	Product	Pack of
Starter Set C (for processing NucleoSpin® 8-well strips under centrifugation)	740684	1
MN Frame	740680	1
Self adhering PE Foil	740676	50

Visit www.mn-net.com for more detailed product information.

6.3 Product use restriction / warranty

All MACHEREY-NAGEL products are designed for their intended use only. They are not intended to be used for any other purpose. The description of the intended use of the products can be found in the original MACHEREY-NAGEL product leaflets. Before using our products, please observe the instructions for use and the safety instructions from the respective Material Safety Data Sheet of the product.

This MACHEREY-NAGEL product is carrying documentation stating specifications and other technical information. MACHEREY-NAGEL warrants to meet the stated specifications. The provided warranty is limited to the data specifications and descriptions as given in the original MACHEREY-NAGEL literature. No other statements or representations, written or oral, by MACHEREY-NAGEL's employees, agents or representatives, except written statements signed by a duly authorized officer of MACHEREY-NAGEL are authorized. They should not be relied upon by the customer and are not a part of a contract of sale or of this warranty.

Liability for all possible damages that occur in any connection with our products is limited to the utmost minimum as stated in the general business terms and conditions of MACHEREY-NAGEL in their latest edition which can be taken from the company's website. MACHEREY-NAGEL does not assume any further warranty.

Products and their application are subject to change. Therefore, please contact our Technical Service Team for the latest information on MACHEREY-NAGEL products. You may also contact your local distributor for general scientific information. Descriptions in MACHEREY-NAGEL literature are provided for informational purposes only.

Last updated: 08/2022, Rev. 04

Please contact:
 MACHEREY-NAGEL GmbH & Co. KG
 Tel.: +49 24 21 969-333
support@mn-net.com

Trademarks:

NucleoSpin® is a registered trademark of MACHEREY-NAGEL GmbH & Co. KG

All used names and denotations can be brands, trademarks, or registered labels of their respective owner – also if they are not special denotation. To mention products and brands is only a kind of information (i.e., it does not offend against trademarks and brands and can not be seen as a kind of recommendation or assessment). Regarding these products or services we can not grant any guarantees regarding selection, efficiency, or operation.

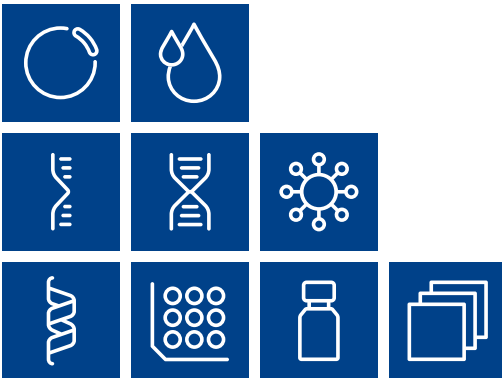

Plasmid DNA

Clean up

RNA

DNA

Viral RNA and DNA

Protein

High throughput

Accessories

Auxiliary tools

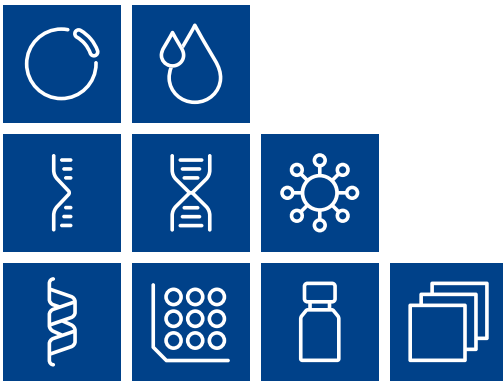

A043540

www.mn-net.com

MACHEREY-NAGEL



 TÜV Rheinland CERTIFIED	Management System EN ISO 13485:2016 ISO 9001:2015	
	www.tuv.com ID 0000056401	

MACHEREY-NAGEL GmbH & Co. KG · Valenciener Str. 11 · 52355 Düren · Germany

DE +49 24 21 969-0 info@mn-net.com

CH +41 62 388 55 00 sales-ch@mn-net.com

FR +33 388 68 22 68 sales-fr@mn-net.com

US +1 888 321 62 24 sales-us@mn-net.com